

DATASHEET

BioTrak™ 645S/745S

Thermal Mass Flow for Wastewater Processes

FEATURES

DEDICATED ACCURACY

- BioSelect™ menu provides field selectable air, methane, and digester gas
- Accuracy $\pm 2.0\%$ of full scale
- Measures gas flow rate in SCFM, MSCFD, KG/HR, and many more
- DigiSense™ sensor design / Swivel probe $\pm 180^\circ$ into four positions
- Wide measurement range up to 1000:1 turndown; 100:1 typical
- Low-end sensitivity for leak detection
- Negligible pressure drop
- 4-20mA for flow rate or temperature; HART communication option
- Choice of second channel: Pulse output for flow / total or Modbus RTU (RS485)
- FM (U.S.) and FMc (CANADA) approved for Class I, Div 1; ATEX/IECEx approved for Zone 1
- NEMA 4X and CE Mark
- Welded, 316 SS sensor and flow body construction, carbon steel flow body optional

FIELD FLEXIBILITY

- Microprocessor based, field-programmable electronics
- Optional on-board 2 line x 16 character, backlit display with configuration panel
- Free BioView™ software available
- USB port to connect to a PC is standard
- BioCal™ calibration validation
- NIST traceable calibration



WASTEWATER

Fast and Flexible Flow Measurement

Sierra's BioTrak 645S/745S shares many of the basic features and benefits of the powerful 645i/745i at a more economical price. The 645S/745S is designed to precisely measure gas flows in aeration, digester, and cogeneration processes found in wastewater applications. It offers the flexibility to monitor multiple gas types at the push of a button, rotate the housing as needed for tight installations, and configure meter settings from advanced software.

Available in Inline or Insertion Models

The BioTrak is available in both insertion (645S) and inline (745S) models. The insertion style has a robust stainless steel probe and is easily installed by drilling a hole in the pipe and welding on a NPT coupling. A compression fitting secures the probe in place. It is supplied with 316 stainless steel wetted materials standard. The inline style flow meters are available in both stainless steel and carbon steel with NPT and 150lb flange options. A USB port to connect to a computer or laptop is standard for insertion and inline configurations; interface options include HART or Modbus RTU (RS485).

Thermal Mass Flow Meters You Can Trust

The BioTrak measures gas flow rate in standard units without the need for temperature or pressure compensation. It provides an isolated 4-20mA output (with a HART option) and a selection of pulse or Modbus RTU (RS485) for a second channel.

Sierra's BioTrak flow meters use a constant temperature differential (constant ΔT) technology to measure the mass flow rate of gases. The thermal mass flow sensor consists of two Resistance Temperature Detectors (RTD's). The Reference RTD measures the gas temperature. Meanwhile, the instrument electronics heat the mass flow sensor, or heated element, to a constant temperature differential (constant ΔT) above the gas temperature and measures the cooling effect of the gas flow. The electrical power required to maintain a constant temperature differential is directly proportional to the mass flow rate of the gas.



PERFORMANCE SPECIFICATIONS

Flow Accuracy

±2.0% of full scale

Accuracy specification applies to customer's selected flow range

Maximum range: 15 to 25,000 SFPM (0.07 to 120 NMPS)

Minimum range: 15 to 500 SFPM (0.07 to 2.4 NMPS)

Straight, unobstructed pipe requirement

- 645S Insertion: 15 diameters upstream 10 downstream
- 745S Inline: 8 diameters upstream, 4 downstream

Flow Repeatability

±0.2% of full scale

Flow Response Time

0.8 seconds (one time constant)

Temperature Accuracy

±1° F (±0.6° C)

Calibration

Factory Calibration to NIST traceable standards

BioCal™

In-situ, operator-initiated calibration validation

OPERATING SPECIFICATIONS

BioSelect™ Gas Selections

Pure gas menu or digester gas mix to suit wastewater applications.

Gases: Air, Methane, and Digester Gas.

Gas Pressure

Maximum gas pressure at 100°F

Insertion: 740 psig (51 barg)

316 SS inline w/NPT ends: 500 psig (34 barg)

316 SS inline w/150lb flanges: 230 psig (16 barg)

CS inline w/NPT ends: 500 psig (34 barg)

CS inline w/150lb flanges: 285 psig (20 barg)

Retractor: 150 psig (10.3 barg)

Notes: Check with factory for higher pressure options.

With Teflon Ferrule option, maximum gas pressure is 60 psig (4.1 barg).

Pressure ratings stated for temperature of 100°F (38°C).

Temperature

DigiSense™ - sensor . . . -40°C to 250°F (-40°C to 121°C)

Enclosure -40°C to 158°F (-40°C to 70°C)*

*NOTE: Display dims below -4°F (-20°C); function returns once temperature rises again.

Flow Velocity Range

15 to 25,000 SFPM at 70°F (0.07 to 120 NMPS at 0°C)

Turndown: up to 1000:1; 100:1 typical

Flow Ranges - 645S Insertion Meters

Pipe Diameter	SCFM	MSCFD	NM3/Hr
1.5" (40mm)	0 - 354	0 - 510	0 - 558
2" (50mm)	0 - 583	0 - 840	0 - 920
2.5" (63mm)	0 - 830	0 - 1,310	0 - 1,200
3" (80mm)	0 - 1,280	0 - 1,840	0 - 2,020
4" (100mm)	0 - 2,210	0 - 3,180	0 - 3,480
6" (150mm)	0 - 5,010	0 - 7,210	0 - 7,910
8" (200mm)	0 - 8,680	0 - 12,500	0 - 13,700
10" (250mm)	0 - 13,600	0 - 19,600	0 - 21,450
12" (300mm)	0 - 19,400	0 - 27,900	0 - 30,600

NOTE: To determine if the 645S will operate accurately in other pipe sizes, divide the maximum flow rate by the pipe area. The application is acceptable if the resulting velocity is within the velocity range above.

OPERATING SPECIFICATIONS continued

Flow Ranges - 745S Inline Meters

Pipe Diameter	SCFM	MSCFD	NM3/Hr
0.75"	0 - 93	0 - 134	0 - 146
1"	0 - 150	0 - 216	0 - 237
1.25"	0 - 260	0 - 374	0 - 410
1.5"	0 - 354	0 - 510	0 - 558
2"	0 - 583	0 - 840	0 - 920
2.5"	0 - 830	0 - 1,310	0 - 1,200
3"	0 - 1,280	0 - 1,840	0 - 2,020
4"	0 - 2,210	0 - 3,180	0 - 3,480
6"	0 - 2,500	0 - 3,600	0 - 3,950

NOTE: Consult factory for flow ranges above those listed. Inline meters above 2,500 SCFM (3,950 NM3/H) may require third party calibration. Contact Sierra Instruments.

Relative Humidity

90% RH maximum; non-condensing

Units of Measurement (field-selectable)

SCFM, SCFH, NM3/M, NM3/H, NM3/D, NLPS, NLP, NLP, MCFD, MSCFD, SCFD, MMSCFD, MMSCFM, SM3/D, SM3/H, SM3/M, LB/S, LB/M, LB/H, LB/D, KG/S, KG/M, KG/H, SLP, MT/H

Input Power

12 to 28 VDC, 6 watts

Full input power range: 10 to 30 VDC.

20 Watt or greater power supply is recommended.

Outputs

Channel 1: Standard isolated 4-20mA output for flow or temperature; fault indication per NAMUR NE43; HART communication option.

Channel 2: Option of pulse output or Serial Communication (Modbus RTU (RS485))

Isolated pulse output: 5 to 24VDC, 20mA max., 0 to 100Hz for flow (the pulse output can be used as an isolated solid state output for alarms).

Serial Communication

USB for connecting to a laptop or computer is standard.

Optional isolated communication output Modbus RTU (RS-485) or HART communication

Free PC-based software tool - BioView™ - provides complete configuration, remote process monitoring, and data logging functions.

4-20mA and Pulse Verification

Simulation mode used to align 4-20mA output and pulse output (if ordered) with the input to customer's PLC/DCS.

PHYSICAL SPECIFICATIONS

Probe Diameter

3/4-inch

Sensor Material

316 stainless steel

Enclosure

NEMA 4X, aluminum, dual 3/4-inch FNPT conduit entries.

SOFTWARE

Use BioSelect™ for easy field setup

Use BioCal™ to validate meter functions

Use BioView™ to access all meter configuration & Data logging

645S Insertion Meter Dimensions

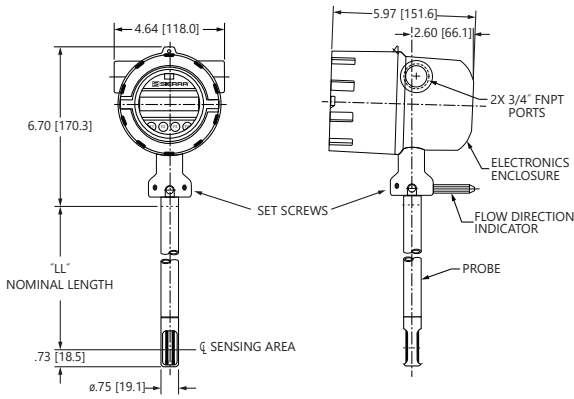

745S Inline Meter with Flow Body NPT End Connections Dimensions

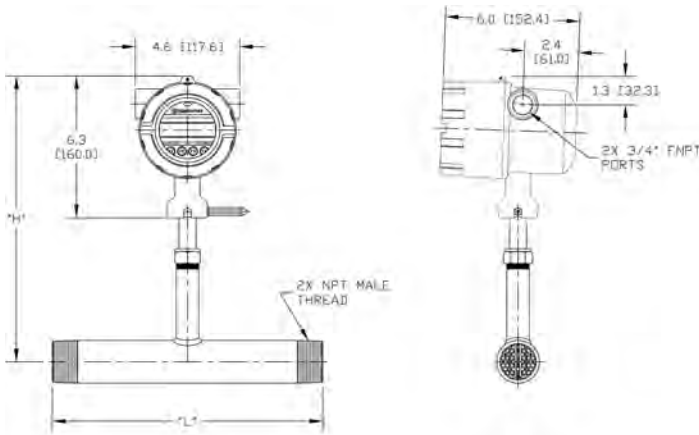

745S Inline Meter with Body 150 lb RF Flange End Connections Dimensions

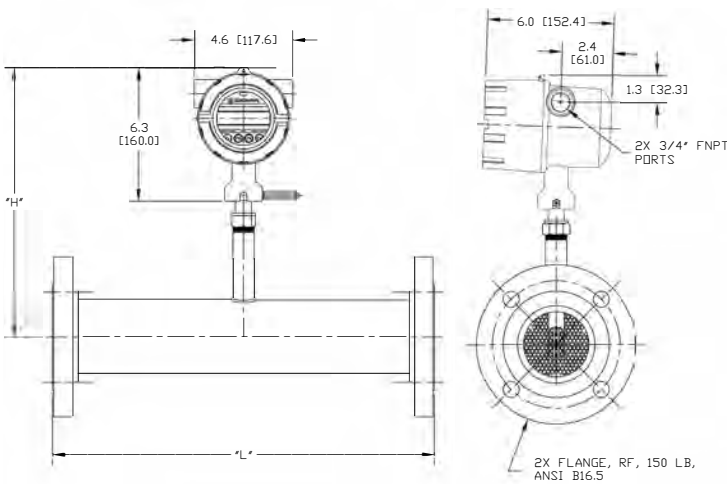

645S INSERTION STYLES

Standard Probe Lengths in Inches (cm) =

6.0 (15.2)	9.0 (22.9)
12.0 (30.5)	15.0 (38.1)
18.0 (45.7)	24.0 (61.0)
30.0 (76.2)	36.0 (91.4)

Assuming there is no insulation or retractor, Sierra recommends the following probe lengths:

Pipe Size	Probe Length
1.5" (40mm) to 6" (150mm)	6-inch
8" (200mm) to 12" (300mm)	9-inch
14" (350mm) to 18" (450mm)	12-inch

Equation for Selecting Insertion Flow Meter Probe Length.

Probe length = 1/2 pipe ID (in inches) + 3" + thickness of insulation (if any) + 10" (for retractor if supplied). Round up to the next standard probe length available.

Note: Contact Sierra for longer probes.

745S INLINE STYLES

Inline pipe sizes, materials, and end connections are listed in the table below.

Inline pipe sizes in Inches =

0.75	1.00	1.25
○ ● ◐ ◑	○ ● ◐ ◑	○ ● ◐ ◑
○ ● ◐ ◑	○ ● ◐ ◑	○ ● ◐ ◑
○ ● ◐ ◑	○ ● ◐ ◑	○ ● ◐ ◑

○= SS ●= CS ◐= NPT Ends ◑= 150lb flanges

Note: 745S inline flow bodies include built-in flow conditioners. FlowTrak Flow Conditioners are available as an option for 645S insertion flow meters.

Probe Diameter

Probe diameter 3/4-inch for insertion and inline flow meters.

APPROVALS

CE Mark

EMC Directive: 2014/30/EU
 Electrical Equipment for Measurement, Control and Lab Use:
 EN61326-1:2013
 Pressure Equipment Directive: 2014/68/EU Article 13
 Weld Testing: EN ISO 15614-1 and EN ISO 9606-1, ASME B31.3

FM (FM21US0123X) & FMc (FM21CA0089X)

Class I, Division 1, Groups B, C, D;
 Class II, Division 1, Groups E, F, G;
 Class III, Division 1; T4, Ta = -40° to 70°C;
 Class I, Zone 1, AEx/Ex db IIB + H2 T4; Gb Ta = -40°C to 70°C; Type 4X,
 IP66/67

ATEX (FM16ATEX0013X)

II 2 G Ex db IIB + H2 T4; Gb Ta = -40°C to 70°C; IP66/67
 II 2 D Ex tb IIIC T135°C; Db Ta = -40°C to 70°C; IP66/67

IECEX (IECEX FMG 16.0010X)

Ex d IIB + H2 T4; Gb Ta = -40°C to 70°C; IP66/67
 Ex tb IIIC T135°C; Db Ta = -40°C to 70°C; IP66/67

ATEX and IECEX Standards

EN IEC 60079-0	IEC 60079-0
EN 60079-1	IEC 60079-1
EN 60079-31	IEC 60079-31
EN 60529 +A1 +A2	IEC 60529

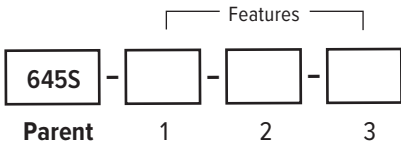

Instructions: To order a 645S, please fill in each feature number block by selecting the codes from the corresponding features below.

Notes: The Parent Model Number and one of each Feature must be specified. Example: 645S-09I-DD-RS

Parent Number	
645S	Insertion Mass Flow meter; includes 4-20mA output and USB serial communication

Feature 1: Probe	
06I	Insertion meter with 6-inch probe
09I	Insertion meter with 9-inch probe
12I	Insertion meter with 12-inch probe
15I	Insertion meter with 15-inch probe
18I	Insertion meter with 18-inch probe
24I	Insertion meter with 24-inch probe
30I	Insertion meter with 30-inch probe
36I	Insertion meter with 36-inch probe
15R	15" probe w/ 150-psi retractor & full port valve, 1" male NPT, 316 SS wetted parts
18R	18" probe w/ 150-psi retractor & full port valve, 1" male NPT, 316 SS wetted parts
24R	24" probe w/ 150-psi retractor & full port valve, 1" male NPT, 316 SS wetted parts
30R	30" probe w/ 150-psi retractor & full port valve, 1" male NPT, 316 SS wetted parts
36R	36" probe w/ 150-psi retractor & full port valve, 1" male NPT, 316 SS wetted parts

Feature 2: Display	
D0	No display & configuration panel
DD	Include rate/total display & configuration panel

Feature 3: Outputs and Serial Communication	
P1	4-20mA + Pulse Output
RS	4-20mA + RS485 (Modbus RTU - Field selectable)
BH	4-20mA / HART + Pulse Output

Notes: See separate model code document for FlowTrak Flow Conditioners for use with insertion style flow meters.

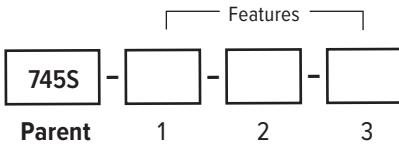

Instructions: To order a 745S, please fill in each feature number block by selecting the codes from the corresponding features below.

Notes: The Parent Model Number and one of each Feature must be specified. Example: 745S-075P-DD-P1

Parent Number	
745S	Inline Mass Flow meter; includes 4-20mA output and USB serial communication

Feature 1: 316 Stainless Steel Flow Body	
075P	3/4 inch flow body (schedule 40), male NPT ends, 12" face-to-face length
10P	1 inch flow body (schedule 40), male NPT ends, 12" face-to-face length
125P	1-1/4 inch flow body (schedule 40), male NPT ends, 12" face-to-face length
15P	1-1/2 inch flow body (schedule 40), male NPT ends, 12" face-to-face length
20P	2 inch flow body (schedule 40), male NPT ends, 12" face-to-face length
25P	2-1/2 inch flow body (schedule 40), male NPT ends, 18" face-to-face length
30P	3 inch flow body (schedule 40), male NPT ends, 18" face-to-face length
075F	3/4 inch flow body (schedule 40), 150# RF flange ends, 12" face-to-face length
10F	1 inch flow body (schedule 40), 150# RF flange ends, 12" face-to-face length
125F	1-1/4 inch flow body (schedule 40), 150# RF flange ends, 12" face-to-face length
15F	1-1/2 inch flow body (schedule 40), 150# RF flange ends, 12" face-to-face length
20F	2 inch flow body (schedule 40), 150# RF flange ends, 12" face-to-face length
25F	2-1/2 inch flow body (schedule 40), 150# RF flange ends, 18" face-to-face length
30F	3 inch flow body (schedule 40), 150# RF flange ends, 18" face-to-face length
40F	4 inch flow body (schedule 40), 150# RF flange ends, 18" face-to-face length**
60F	6 inch flow body (schedule 40), 150# RF flange ends, 24" face-to-face length**

Feature 1: A106 Grade B Carbon Steel Flow Body (w/ A105 flanges if ordered)	
20PC	2 inch flow body (schedule 40), male NPT ends, 12" face-to-face length
25PC	2-1/2 inch flow body (schedule 40), male NPT ends, 18" face-to-face length
30PC	3 inch flow body (schedule 40), male NPT ends, 18" face-to-face length
20FC	2 inch flow body (schedule 40), 150# RF flange ends, 12" face-to-face length
25FC	2-1/2 inch flow body (schedule 40), 150# RF flange ends, 18" face-to-face length
30FC	3 inch flow body (schedule 40), 150# RF flange ends, 18" face-to-face length
40FC	4 inch flow body (schedule 40), 150# RF flange ends, 18" face-to-face length**
60FC	6 inch flow body (schedule 40), 150# RF flange ends, 24" face-to-face length**

Feature 2: Display	
D0	No display & configuration panel
DD	Include rate/total display & configuration panel

Feature 3: Outputs and Serial Communication	
P1	4-20mA + Pulse Output
RS	4-20mA + RS485 (Modbus RTU - Field selectable)
BH	4-20mA / HART + Pulse Output



www.proconit.com.au
sales@proconit.com.au

1/119 Delta Street Geebung QLD 4034
07 3823 1922