

## RFM series Field Termination and Intrinsic Safety Barrier Modules



### Key features

- Field termination and intrinsic safety barrier modules for use with PSM APT1000 smart hydrostatic level transmitters
- Flexible and modular system simplifies and reduces the cost of power, signal and data wiring loops
- Lightweight aluminium (below deck mounting) or painted steel construction (above deck mounting)
- A single RFM-ISR safely barrier provides protection for all connected transmitters



## **Simplify the installation and connection of APT1000 intelligent transmitters.**

The RFM series is used with PSM APT1000 smart hydrostatic level transmitters to provide both simple multi-drop network connections and full compliance with ATEX Intrinsic Safety standards where required.

RFM is offered with various configurations from simple termination boxes to fully approval barrier systems for use in hazardous area applications.

Housings are either offered in a lightweight IP67 aluminium enclosure for below deck mounting, or a rugged IP67 steel enclosure suitable for harsh environments or open deck mounting.

Cable entry is via 6 x M20 glands and the housing is vented to atmosphere via waterproof sintered vent plugs.

## **RFM-1 & RFM-4**

Provide convenient termination points for the ict 1000 connections for input power and digital signal cabling, and “pass-through” connections to feed the power and signal cable to the next RFM.

Digital multi-drop communication means the user can link multiple RFM units using a simple 4 core connection dramatically saving on the cable required compared to conventional 4-20mA loops.

RFM-1 & RFM-4 and their connected ict 1000 transmitters can be mounted in the hazardous area in Intrinsically safe applications when installed in conjunction with RFM-ISR modules.

## **Hazardous area installation RFM-ISR**

RFM-ISR provides intrinsically safe power and Modbus data transmission capabilities to a network of ict 1000 transmitters using zener barriers.

Any power supply between 15 to 35V DC can be used and RFM-ISR will protect up to 100 APT1000 transmitters running in digital mode and terminated using the RFM-1 or RFM-4.

## Application example: comparison of a multi-tank installation using analogue vs. Modbus digital communications

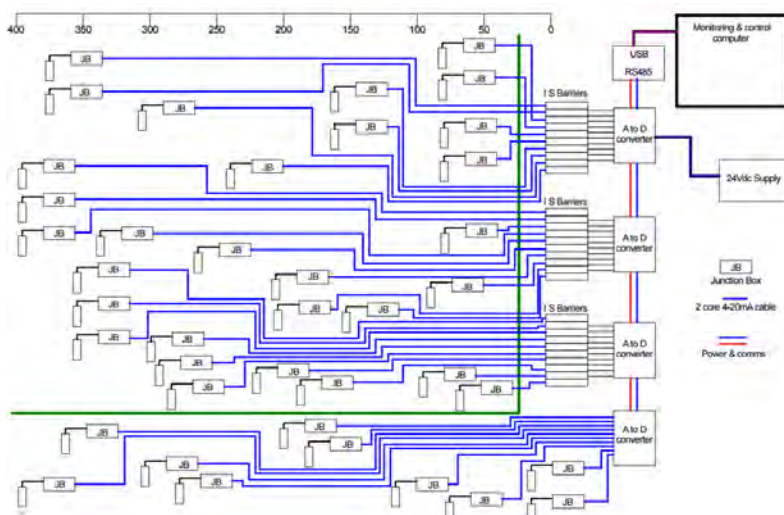

### Conventional Analogue System

- Individual 4-20mA signals each require a separate cable and safety Barrier
- Signals require conversion from analogue to digital meaning additional hardware and reduced resolution

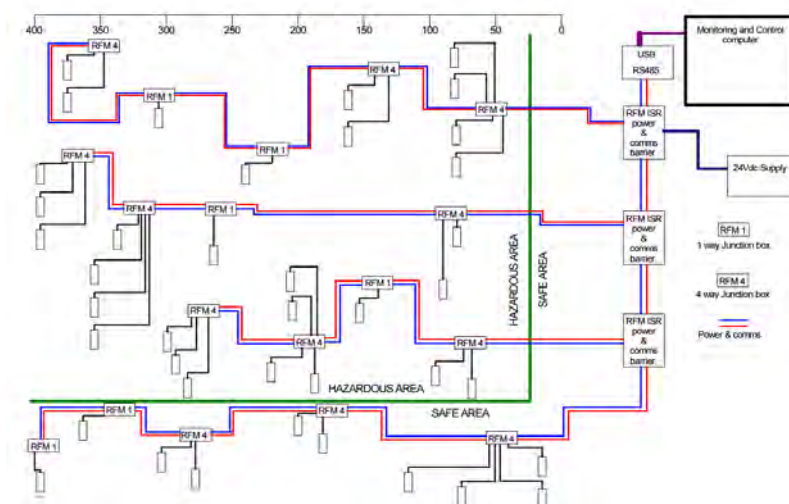

### Scanjet PSM Digital System

- Direct Modbus output from sensor via a Multi-drop 4-core cable to the display system reducing cabling requirements
- No requirement for conversion to digital signal. Sensor communicates direct with the display system reducing hardware and costs.
- A single Safety barrier protects power and communication lines for all sensors on each network

Using APT1000 smart hydrostatic level transmitters connected with RFM & RFM-ISR modules to a Scanjet PSM VPM Display System via Modbus digital communications provides the following benefits:

- Simple installation - a single cable replaces multiple power and analogue signal loops
- Reduced build costs - remove the need for copper cable and junction boxes
- Ease of commissioning - transmitter setup and diagnostics accessible at any network point
- Decreased weight - removal of copper cable loops improves ship's operating efficiency

© PSM INSTRUMENTATION LTD

Data Sheet Ref: DAT 30J May2022

**GA drawing (epoxy coated cast aluminium enclosure)**

**Specifications**

Ingress Protection:  
IP67

Cable entry:  
M20 Gland—quantity as  
required

RFM ISR Supply:  
15-35VDC

Operating Temperature  
-10 to +50 °C

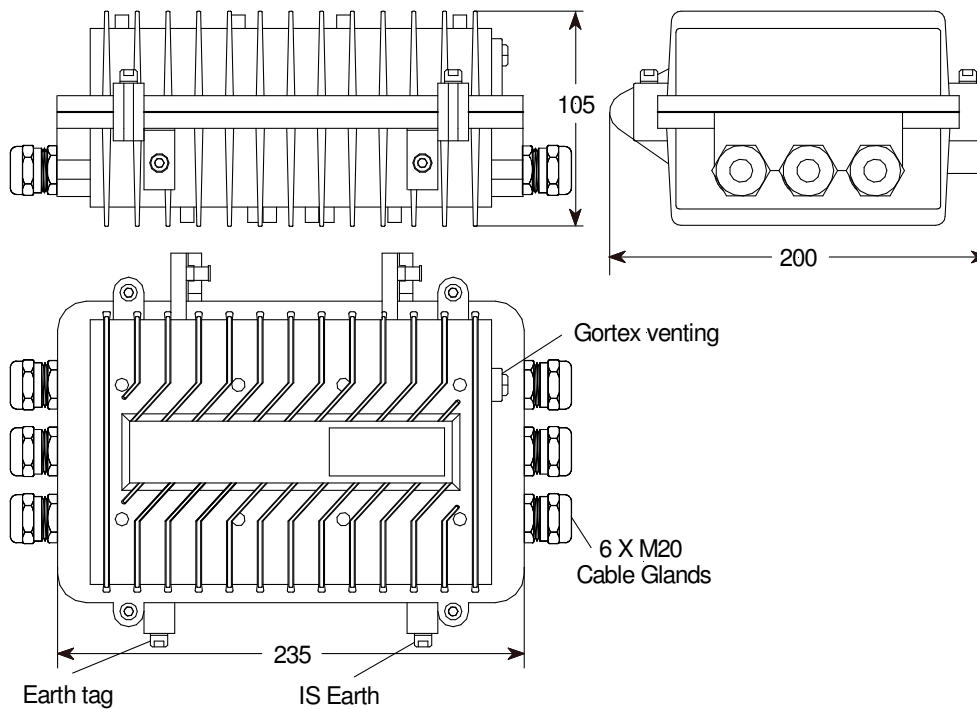

**GA drawing (painted mild steel enclosure)**

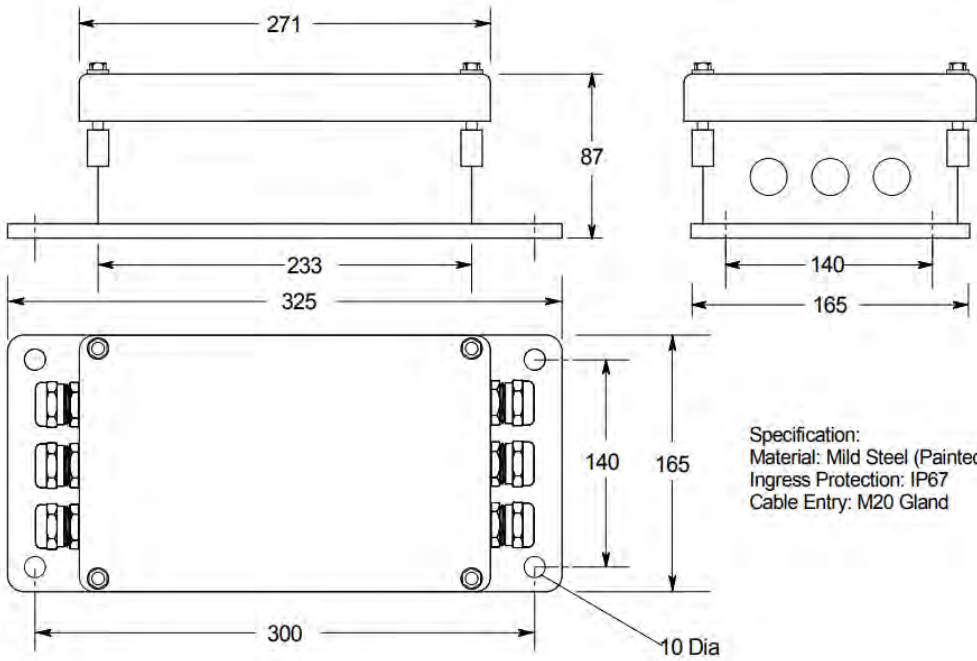

Specification:  
 Material: Mild Steel (Painted)  
 Ingress Protection: IP67  
 Cable Entry: M20 Gland

© PSM INSTRUMENTATION LTD

Data Sheet Ref: DAT 30J May 2022