

# Sierra 820 Series Top-Trak™ Mass Flow Meters

Models: 820, 820S, 822, 822S, 824, 824S, 826 and 827



## Instruction Manual

Part Number IM-82  
Revision H, November 2017



## GLOBAL SUPPORT LOCATIONS: WE ARE HERE TO HELP!

### CORPORATE HEADQUARTERS

5 Harris Court, Building L Monterey, CA 93940  
Phone (831) 373-0200 (800) 866-0200 Fax (831) 373-4402  
[www.sierrainstruments.com](http://www.sierrainstruments.com)

### EUROPE HEADQUARTERS

Bijlmansweid 2 1934RE Egmond aan den Hoef The Netherlands  
Phone +31 72 5071400 Fax +31 72 5071401

### ASIA HEADQUARTERS

Second Floor Building 5, Senpu Industrial Park  
25 Hangdu Road Hangtou Town  
Pu Dong New District, Shanghai, P.R. China  
Postal Code 201316  
Phone: + 8621 5879 8521 Fax: +8621 5879 8586

## IMPORTANT CUSTOMER NOTICE: OXYGEN SERVICE

Sierra Instruments, Inc. is not liable for any damage or personal injury, whatsoever, resulting from the use of Sierra Instruments standard mass flow meters or controllers for oxygen gas. You are responsible for determining if this mass flow meter or controller is appropriate for your oxygen application. You are responsible for cleaning the mass flow meter or controller to the degree required for your oxygen flow application.

## © COPYRIGHT SIERRA INSTRUMENTS 2016

No part of this publication may be copied or distributed, transmitted, transcribed, stored in a retrieval system, or translated into any human or computer language, in any form or by any means, electronic, mechanical, manual, or otherwise, or disclosed to third parties without the express written permission of Sierra Instruments. The information contained in this manual is subject to change without notice.

## TRADEMARKS

Top-Trak™ and Cal-Bench™ is a Registered Trademark of Sierra Instruments, Inc. Other product and company names listed in this manual are trademarks or trade names of their respective manufacturers.

## Table of Contents

### Chapter 1 Introduction

Introduction .....	1-1
Using this Manual .....	1-1
Safety Information .....	1-2
Receipt of System Components .....	1-2
Technical Assistance.....	1-2
Top Trak Features .....	1-3
The 820 Series Flow Sensing Principle .....	1-4

### Chapter 2 Installation

Installation Overview .....	2-1
Installing the Transducer.....	2-2
Compression Fittings .....	2-2
VCO Fittings .....	2-2
VCR Fittings.....	2-3
All 1/2-inch Size Connections.....	2-3
Wiring the Transducer .....	2-4
Standard 0-5 VDC Output Signal Wiring.....	2-5
Optional 4-20 mA Output Signal Wiring.....	2-5
Remote Display Installation.....	2-6

### Chapter 3 Operation

Transducer Operation.....	3-1
Transducer Accuracy .....	3-1
Referencing the Transducer to Non-Standard Conditions ....	3-2
Transducer Over-Ranging .....	3-2
Zero and Span Adjustments.....	3-3
Totalizer Option .....	3-4

### Chapter 4 Maintenance and Repair

Transducer Cleaning .....	4-1
Flow Path Cleaning Model 822/824.....	4-2
Inlet and Outlet Screens .....	4-2
Laminar Flow Element .....	4-3
Flow Path Cleaning Model 826/827.....	4-4
Laminar Flow Element .....	4-4
Flow Path Cleaning Model 822-S/824-S .....	4-5
Laminar Flow Element .....	4-5
Sensor Cleaning and Inspection .....	4-8
Transducer Calibration.....	4-9
Transducer Troubleshooting.....	4-11
Returning Equipment to the Factory .....	4-13

## Appendix A Conversion Formulas and Gas Tables

## Appendix B 822/824 Product Specifications

## Appendix C 822S/824S Product Specifications

## Appendix D 826/827 Product Specifications

## List of Figures

1-1. Top-Trak Features (Typical).....	1-3
1-2. Flow Paths through the Transducer.....	1-4
1-3. Flow Measuring Principle.....	1-4
2-1. Piping Requirements for 1/2-inch Size Connections ..	2-3
2-2. Transducer D-Connector Pin Assignments .....	2-4
2-3. Standard 0-5 VDC Output Signal Wiring.....	2-5
2-4. Single Transducer Current Loop Connection.....	2-5
2-5. Multiple Transducer Current Loop Connections.....	2-6
2-6. Mounting the Remote Display.....	2-6
4-1. Model 822/824 Flow Components.....	4-2
4-2. Correct LFE Position .....	4-3
4-3. Model 826/827 Flow Components .....	4-4
4-4. Low Flow Transducer LFE Cleaning.....	4-5
4-5. Medium Flow Transducer LFE Cleaning .....	4-6
4-6. High Flow Transducer LFE Cleaning.....	4-7
4-7. Printed Circuit Board Component Locations .....	4-11

## Cautions

**Caution!** Only qualified personnel should install the transducer.

**Caution!** Do not supply +DC power at the D-connector while using a power supply at the power jack. Both supplies may be damaged.

**Caution!** Operating a 12 VDC transducer at 24 VDC will cause equipment damage.

**Caution!** Only qualified personnel should perform transducer service, calibration or troubleshooting procedures.

**Caution!** When using toxic or corrosive gases, purge the unit thoroughly with inert dry gas before disconnecting from the gas line.

**Caution!** Printed circuit boards are sensitive to electrostatic discharge. To avoid damaging the board, follow these precautions to minimize the risk of damage:

- before handling the assembly, discharge your body by touching a grounded, metal object
- handle all cards by their edges unless otherwise required
- when possible, use grounded electrostatic discharge wrist straps when handling sensitive components



## Chapter 1 Introduction

This instruction manual covers the installation, operation and maintenance of Sierra's 820 Series product line including the following Top-Trak<sup>™</sup> Models:

- 822 Mass Flow Meter with display (nylon flow body)
- 824 Mass Flow Meter without display (nylon flow body)
- 826 Hi-Flow Meter with display (aluminum flow body)
- 827 Hi-Flow without display (aluminum flow body)
- 822-S Mass Flow Meter with display (stainless steel flow body)
- 824-S Mass Flow Meter without display (stainless steel flow body)

Sierra's Top-Trak<sup>™</sup> Mass Flow Meters are designed for precise measurement of gas mass flow. The 820 Series offers a broad range of sizes and process connections for flexibility and versatility. The primary standard calibration ensures starting point accuracy and NIST traceability. The meter's 0-5 VDC or 4-20 mA output signal is provided for recording, data-logging or control. The optional display reads the mass flow rate directly in engineering units or percentage of full scale.

### *Using This Manual*

This manual is organized into four chapters:

- Chapter 1 includes the introduction and theory of operation
- Chapter 2 provides installation and wiring instructions
- Chapter 3 describes transducer operation and features
- Chapter 4 covers maintenance, calibration and troubleshooting

Gas tables and conversion formulas are found in Appendix A. The product specifications and dimensional drawings are found in Appendix B.

Throughout this manual, we use the word *transducer* as a generic term to represent all models of Sierra's 820 Series Top-Trak Mass Flow Meters.

## *Safety Information*

Caution and warning statements are used throughout this book to draw your attention to important information.



### **Warning!**

This statement appears with information that is important to protect people and equipment from damage. Pay very close attention to all warnings that apply to your application.



### **Caution!**

This statement appears with information that is important for protecting your equipment and performance. Read and follow all cautions that apply to your application.

## *Receipt of System Components*

When receiving a Sierra transducer, carefully check the outside packing carton for damage incurred in shipment. If the carton is damaged, notify the local carrier and submit a report to the factory or distributor. Remove the packing slip and check that all ordered components are present and match your specifications (as ordered). Make sure any spare parts or accessories are not discarded with the packing material. Do not return any equipment to the factory without first contacting Sierra Customer Service.

## *Technical Assistance*

If you encounter a problem with your transducer, review the configuration information for each step of the installation, operation and set up procedures. Verify that your settings and adjustments are consistent with factory recommendations. Refer to Chapter 4, Troubleshooting, for specific information and recommendations.

If the problem persists after following the troubleshooting procedures outlined in Chapter 4, contact Sierra Instruments by fax or by E-mail (see inside front cover). For urgent phone support you may call (800) 866-0200 or (831) 373-0200 between 8:00 a.m. and 5:00 p.m. PST. In Europe contact Sierra Instruments bv at +31 20 6145810. When contacting Technical Support, make sure to include this information:

- the flow range, serial number, Sierra order number and model number (all marked on the transducer nameplate)
- the problem you are encountering and any corrective action taken
- application information (gas, pressure, temperature, pipe and fitting configuration)



## Top-Trak Features

Standard Top-Trak Mass Flow Meters require a 12 to 15 VDC external power source (24 VDC input power optional). The transducer's 0 to 5 VDC output signal allows for flow recording, data-logging or control. A 4 to 20 mA output signal is optionally available. Input power and output signal connections are made via the 9-pin subtype D-connector located on the side of the transducer. An additional input power jack is located just below the D-connector. (It is important to connect input power at only one location.)

The transducer shown below is a typical example of a 822 Series Top-Trak Mass Flow Meter. Other models may vary slightly in their appearance but are operationally equivalent.

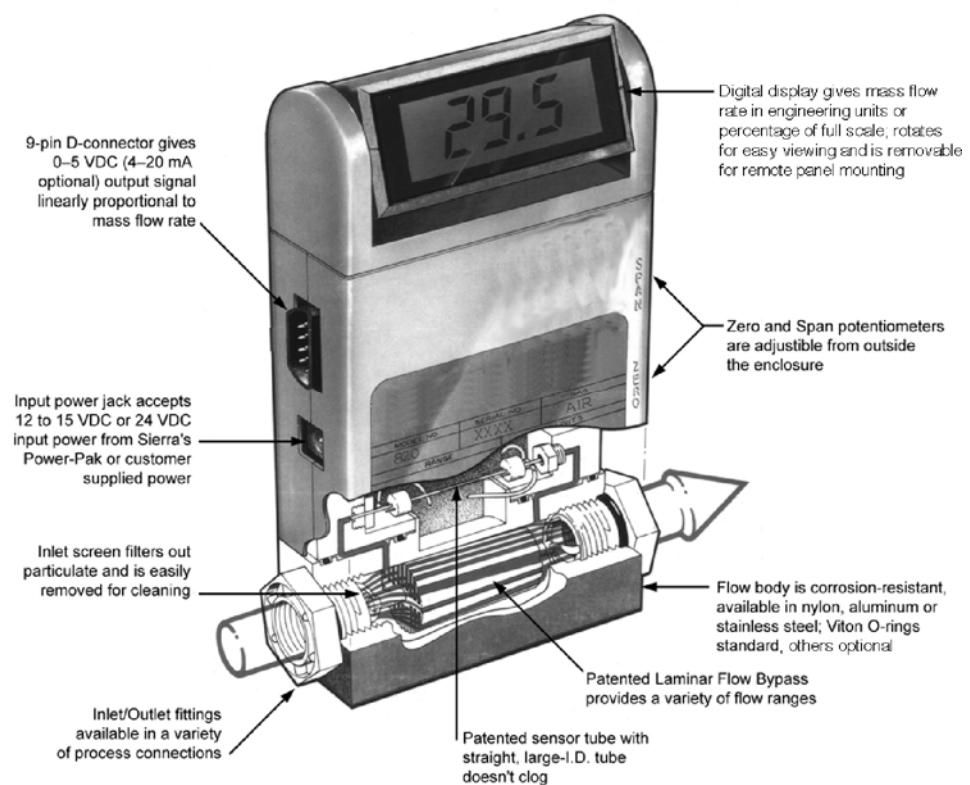

Figure 1-1. Top-Trak Features (Typical)

## The 820 Series Flow Sensing Principle

The operating principle of Top-Trak transducers is based on heat transfer and the first law of thermodynamics. During operation process gas enters the instrument's flow body and divides into two flow paths, one through the sensor tube, the other through the laminar flow element bypass. The laminar flow bypass generates a pressure drop,  $P_1 - P_2$ , forcing a small fraction of the total flow to pass through the sensor tube ( $m_1$ ).

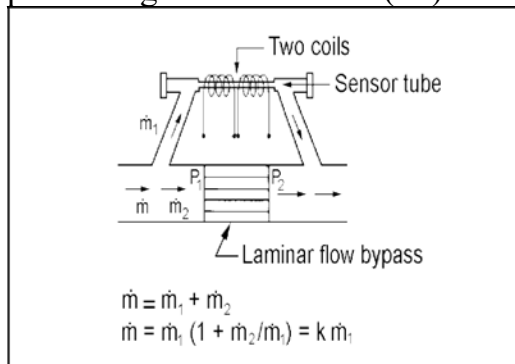

Figure 1-2. Flow Paths through the Transducer

Two resistance temperature detector (RTD) coils around the sensor tube direct a constant amount of heat ( $H$ ) into the gas stream. In actual operation, the gas mass flow carries heat from the upstream coil to the downstream coil. The resulting temperature difference ( $\Delta T$ ) is detected by the RTD coils and gives the output signal. Since the molecules of the gas carry away the heat, the output signal is linearly proportional to gas mass flow.

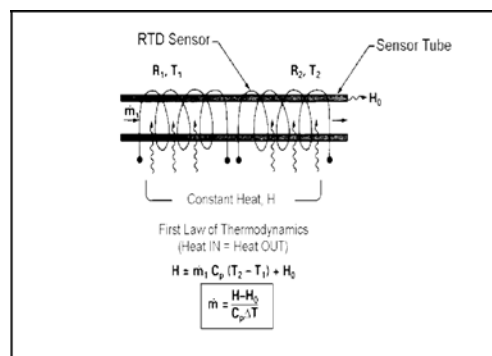

Figure 1-3. Flow Measuring Principle

## Chapter 2 Installation

### Installation Overview

To ensure a successful installation, inlet and outlet tubing should be clean and free from burrs or rims caused by cutting prior to plumbing the transducer into the system. The protective caps covering the inlet/outlet fittings should not be removed until immediately prior to installation.

Before installing the transducer, verify the following:

1. Make sure the installation site meets the specific operating parameters recorded on the transducer's nameplate. Each transducer is factory-configured for a specific gas and flow range. If the operating pressure is more than 50 psi (3.4 bar) away from the calibration pressure, it is advisable to return the unit to the factory for re-calibration. (Adjusting zero may be sufficient to remain within specification.)
2. Do not locate the transducer in areas subject to sudden temperature changes, moisture, drafts or near equipment radiating significant amounts of heat. Make sure to allow adequate space for cable connectors and wiring.
3. For 1/2-inch size inlet/outlet process connections on models 826 and 827 make sure the location meets the minimum number of recommended pipe diameters upstream and downstream of the transducer. A minimum of 5 inches (127 mm) upstream and 2-1/2 inches (64 mm) downstream is always recommended. (not necessary for other models)
4. Horizontal mounting is preferable. Vertical mounting is possible with best results achieved when the factory calibration is specifically performed for vertical mounting. In vertical positions zero shift will occur depending on the gas pressure at zero flow.
5. If the gas contains any particulate matter, install an in-line filter prior to the transducer. Recommended filter size: 15 micron for flows of 10 sccm to 30 slpm, 30 micron for above 30 slpm.
6. If a potential over-flow condition exists, insert a valve or critical orifice in the line to limit flow to approximately 25 percent above the full scale range of the meter.
7. Confirm that the transducer o-ring material is compatible with the gas to be measured.
8. For remote displays, confirm the supplied cable is of sufficient length to connect the components.



**Caution!**  
Only qualified personnel should install the transducer.

## Installing the Transducer

Follow the installation instructions that apply to your transducer's process connection. For all 1/2-inch size process connections, observe the piping recommendations given on page 2-3. Before operation, all plumbing should be checked carefully for leaks and the transducer purged with dry nitrogen.

### *Compression Fittings*

1. Position the transducer with the flow direction arrow pointing downstream in the direction of flow.

2. Verify the position of the front and back ferrule. Insert the tubing into the fitting. Make sure that the tubing rests firmly on the shoulder of the fitting and that the nut is finger tight. (Do not mix or interchange parts of tube fittings made by different manufacturers.)

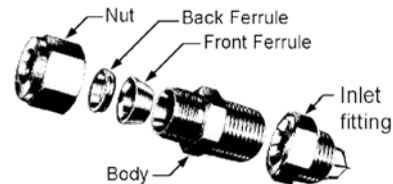

3. **Hold the body steady with a backup wrench.** For 1/2-inch size, tighten the nut 1-1/4 turns from finger tight. For 1/8-inch, 1/4-inch and 3/8-inch sizes, tighten only 3/4 turn from finger tight. **Do not over-tighten!**
4. Check the system's entire flow path thoroughly for leaks. (Do not use liquid leak detectors, instead monitor pressure decay. Over-exposing the transducer to leak detector fluid may damage the unit.)

### *VCO Fittings*

1. Position the transducer with the flow direction arrow pointing downstream in the direction of flow.
2. Install new o-rings compatible with the gas to be used. (Do not mix or interchange parts of tube fittings made by different manufacturers.)
3. **Hold the body steady with a backup wrench.** Tighten the nut finger tight and then 1/4 turn tighter with a wrench. **Do not over-tighten!**
4. Check the system's entire flow path thoroughly for leaks. (Do not use liquid leak detectors, instead monitor pressure decay. Over-exposing the transducer to leak detector fluid may damage the unit.)

### *1/4 inch Female NPT Connections (standard on nylon flow bodies)*

1. Position the transducer with the flow direction arrow pointing in the direction of flow.
2. Use a good quality paste pipe thread sealant. Apply to pipe threads.
3. Tighten the pipe no more than 1 turn past hand-tight. Caution! Do not over-tighten. Damage to the instrument may result.

### *1/2-Inch Size NPT Connections*

1. Install a section of straight pipe at least ten pipe diameters in length upstream of the transducer. Also, allow at least five pipe diameters downstream for accurate operation. DO NOT use reducers. If the preceding components in the flow path create disturbances extend the upstream pipe length.
2. Position the transducer with the flow direction arrow pointing downstream in the direction of flow.
3. Tighten fittings until leak tight (refer to published standards for specific recommendations).
4. Check the system's entire flow path thoroughly for leaks. (Do not use liquid leak detectors, instead monitor pressure decay. Over-exposing the transducer to leak detector fluid may damage the unit.)

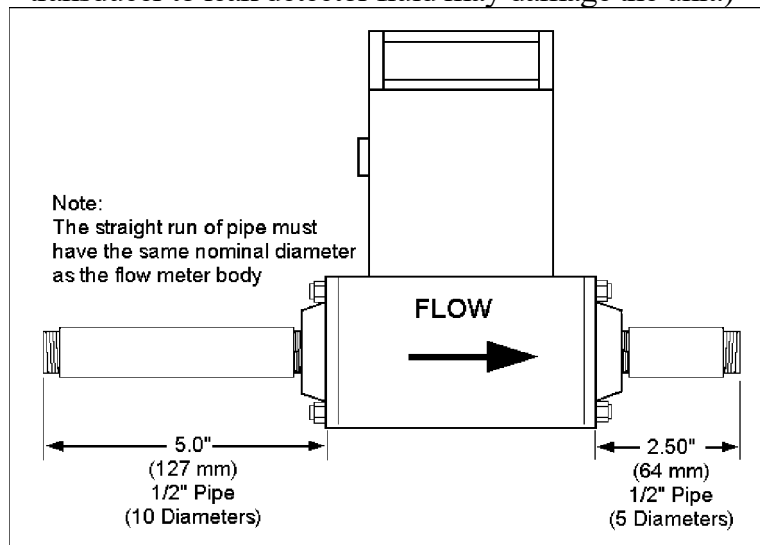

Figure 2-1 Piping Requirements for all 1/2-Inch Size Process Connections

## Wiring the Transducer



Do not supply +DC power at the D-connector while using a power supply at the power jack. Both supplies may be damaged.

Standard Top-Trak<sup>™</sup> transducers require a 12 to 15 VDC power supply (15 VDC nominal, 100 mA maximum). 24 VDC input power is optional. Transducers are connected to the power supply through *either* the dedicated DC power jack or through the 9-pin D-connector located on the side of the enclosure. Before powering the unit, check the transducer's nameplate to confirm input power:

- PV1 = 12 to 15 VDC
- PV2 = 24 VDC



**Caution!**  
Operating a 12 VDC transducer at 24 VDC will cause equipment damage.

**Note:** operating a 24 VDC transducer at 12 to 15 VDC will result in unreliable operation.

The transducer's standard 0 to 5 VDC (4-20 mA optional) output signal is available through the D-connector. The mating connector is included with the transducer. Connection details are given on the following pages.

When the transducer is configured for a remote display, signal connections are made via the 9-pin connector. Input power connections are not included in the standard interface cable. Power connections for the display and the transducer are shared when the connector is wired for a remote display. Optionally the input power can be applied at the power jack (either 12 volts (PV 1) or 24 volts (PV2)). Remote display mounting dimensions are given at the end of this chapter.

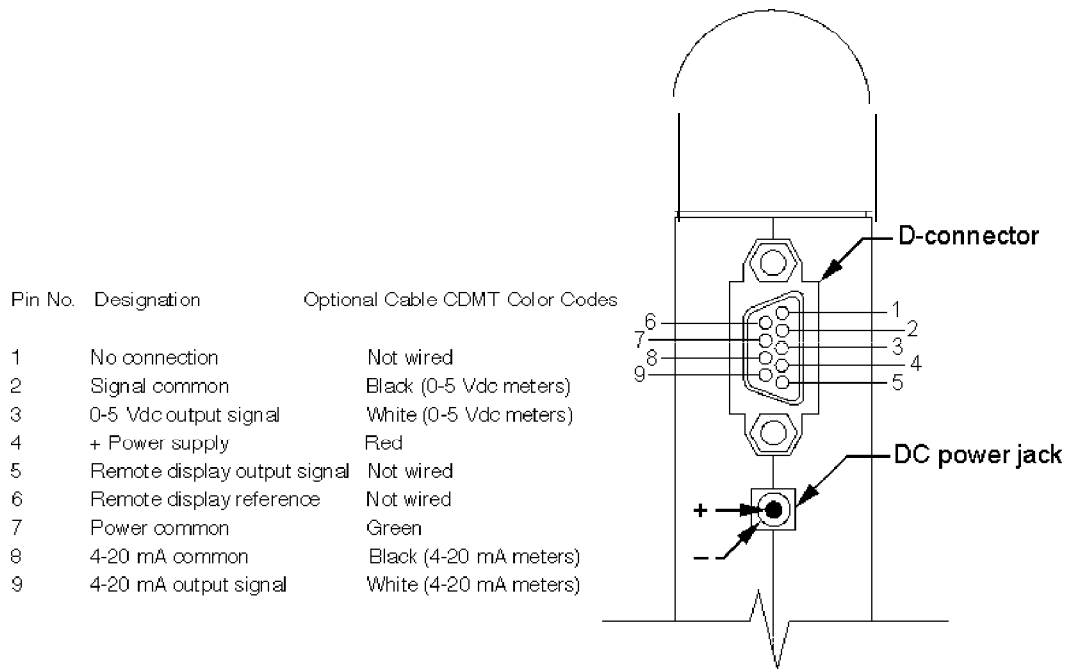

Figure 2-2. Transducer D-Connector Pin Assignments

**Note:** The power jack requires a plug that has a 2.5mm inner diameter and a 5mm outer diameter. The center is positive (+).

### Standard 0-5 VDC Output Signal Wiring

The standard 0-5 VDC output signal flows from Pin 3 (0-5 VDC Out) through the load (1K Ohm minimum) to Pin 7 (Power Common). The figure below is a typical example of input power and output signal connections.

Figure 2-3. Standard 0-5 VDC Output Signal Wiring

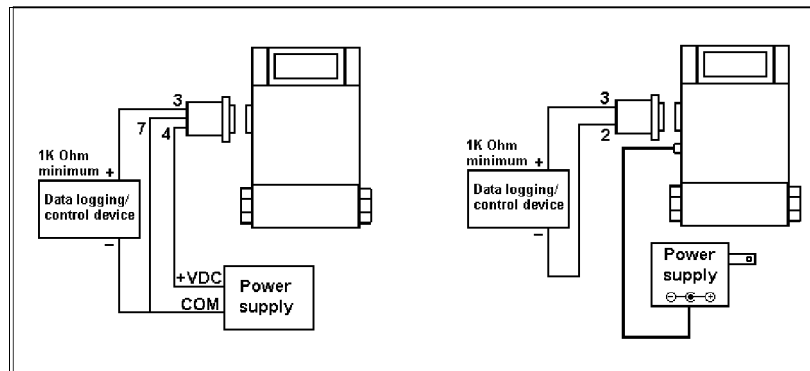

### Optional 4-20 mA Output Signal Wiring

The optional 4-20 mA output signal flows from Pin 9 (4-20 mA Out) through the load (50 to 500 Ohms maximum) to Pin 7 (Power Common). The figure below is a typical example of input power and output signal connections. (Multiple transducer current loop output connections are given on the next page.)

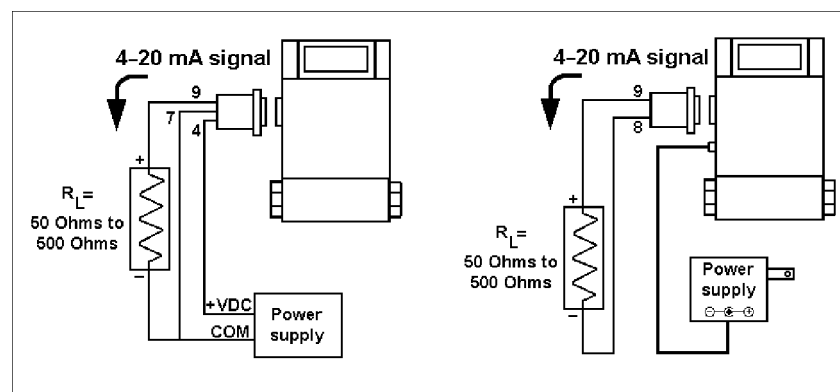

Figure 2-4. Single Transducer Current Loop Connection



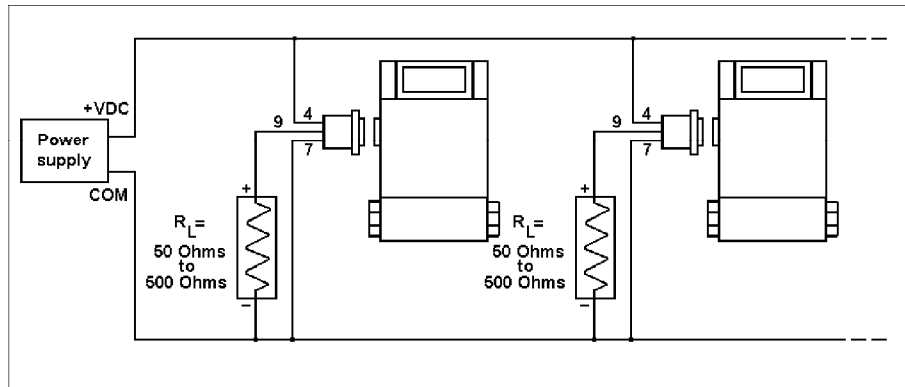

Figure 2-5. Multiple Transducer Current Loop Connections

### Remote Display Installation

Mount the remote display at a convenient location within reach of the supplied interface cable. The maximum cable length is 100 feet (30 m).

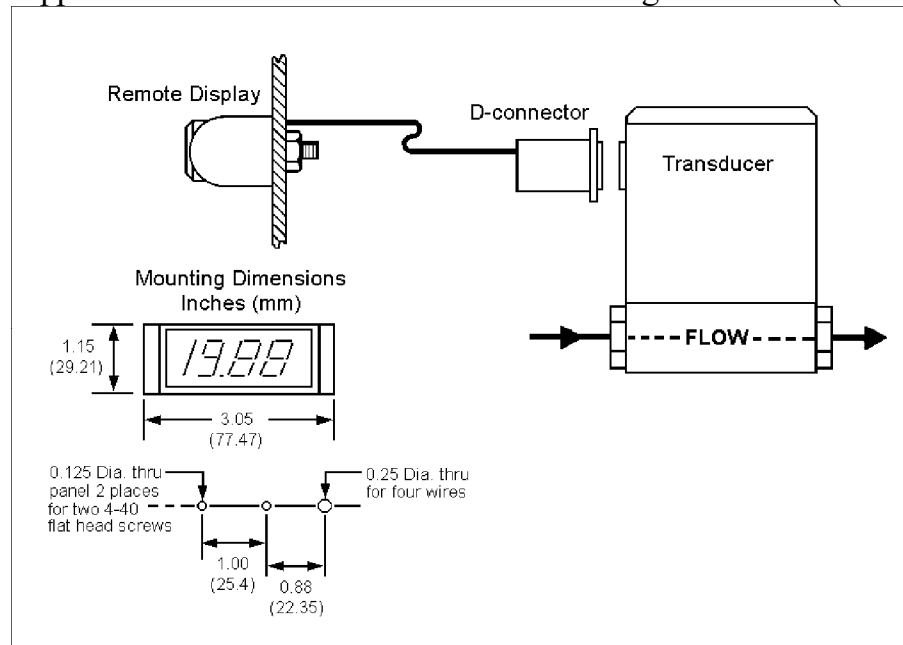

Figure 2-6. Mounting the Remote Display



## Chapter 3 Operation

The output signal of the transducer is either 0-5 VDC (standard) or 4-20 mA (optional). The output signal is linear and proportional to the gas mass flow rate. For example, for a 0-5 VDC output signal, 5.00 VDC is the output signal for the full scale listed on the transducer's nameplate, 2.50 VDC is for one-half of full scale, and 0.00 VDC is for zero flow. For a 4-20 mA output signal, 20.00 mA is the output signal for the full scale, 12.00 mA is for one-half of full scale, and 4.00 mA is for zero flow.

### Transducer Operation

When the transducer is installed and the system has undergone a complete leak check:

1. Apply power. The output signal will be at a high level for the first 10 to 20 seconds while the sensor warms up to its normal operating temperature range. Assuming zero flow, the output signal will then drop to zero (or 4 mA, depending on output configuration). Allow at least thirty minutes of warm-up time.
2. For first-time start ups, perform an initial zero output check as described on page 3-3. After checking the initial zero setting, the transducer is ready to monitor the gas mass flow rate.

### *Transducer Accuracy*

The standard accuracy of Top-Trak is  $\pm 1.5\%$  of full scale. The  $\pm 1.5\%$  of full scale accuracy means that the 0-5 VDC output signal is accurate to within  $\pm 0.075$  VDC. The 4-20 mA output is accurate to within  $\pm 0.24$  mA.

For example, the output signal for zero flow can be as much as  $\pm 0.075$  VDC or  $+0.24$  mA. If the transducer has an output signal at zero flow, as long as it is within either of these two ranges, it does not mean it is malfunctioning.

For transducers with a digital display, the accuracy is simply .015 times the full scale flow rate stated on the nameplate. For example, if the full scale is 10 slpm, the digital display will be accurate to  $\pm 0.15$  slpm. The reading at zero flow may be as much as  $+0.15$  slpm and still be within the stated accuracy specification.

### *Referencing the Transducer to Non-Standard Conditions*

The gas flow rate output of your transducer is referenced to “normal” conditions of 21 °C (70°F) and 760 mm of mercury (1 atmosphere) unless otherwise specified on the certificate of calibration. Check the stated reference conditions of your transducer. If you are comparing your transducer’s output with another type of flow meter, different reference conditions could cause a discrepancy between the flow readings.

For example, the output reading of a Top-Trak will be approximately 7% lower when referenced to 0°C rather than 21°C. To find the flow rate referenced to other standard conditions or the actual temperature and pressure conditions in the pipe where your transducer is located, see Appendix A.

### *Transducer Over-Ranging*

If the flow rate exceeds the full scale value listed on the transducer nameplate, the output signal and digital display (if so equipped) will read a higher value. The transducer is not calibrated for over-ranged flows and will probably be both non-linear and inaccurate. Over-range conditions are indicated by the display and/or output signal going to a level above the full scale range. When the over-range condition is removed, it may take several seconds for the transducer to recover and resume normal operation.

If the supply voltage is only 12 VDC, the over-ranged reading may exceed the full scale value by 10% maximum. If the supply voltage is higher, as with the 24 VDC option, then the output can exceed the full scale by as much as 50%, or more. Digital displays cannot exceed 3-1/2 digits (1999). If the flow rate exceeds 1999, the right-most digits will blank and only the left-hand “1” will appear on the display.

### *Zero and Span Adjustments*

The zero and span potentiometers are accessed through the ports marked on the side of the transducer. Normally, span adjustments are not made unless you are calibrating the transducer. The span adjustment should not be used unless you have a known, precise non-zero flow rate that you wish to match. Before making any zero adjustments, confirm that the system has reached its normal operating temperature and pressure and the transducer is mounted in its final position.

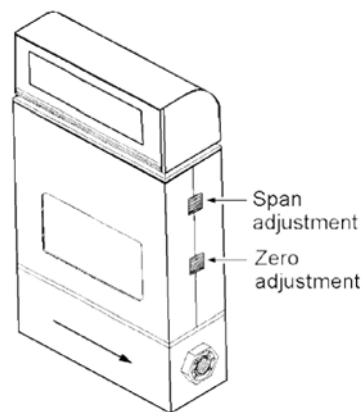

For transducers without the digital display:

1. Power the transducer and allow at least 30 minutes of warm up time before attempting any adjustments. Set gas flow to zero. Confirm that no flow exists.
2. Connect a digital multimeter to Pin 3 (0-5 Out) or, Pin 9 (4-20 Out) and Pin 7 (Power Common). Check the reading. If it does not indicate  $0 \pm .05$  VDC, (or  $4.0 \pm .016$  mA) adjust the zero potentiometer.

Since the output signal does not indicate negative numbers, it is necessary to adjust down from a slightly positive reading. Begin by slowly rotating the zero pot clockwise until a positive reading is indicated. To complete the zero adjustment, slowly turn the pot counterclockwise until zero is achieved, or to the point where output quits changing (may be slightly above zero point in some cases) **DO NOT ADJUST DOWNWARD BEYOND THIS POINT.**

For transducers with the digital display:

1. Power the transducer and allow at least 30 minutes of warm up time before attempting any adjustments. Set gas flow to zero. Confirm that no flow exists.
2. Observe the reading on the digital display. If the reading is greater than 1.0% of full scale, adjust the zero potentiometer.

## 820 Totalizer Operation

The optional 820 totalizer is designed to provide a totalizer function within the digital display of the 820 series. It will display the flow rate, the total flow or both at once. If your instrument has this option, it is described below. Note the flow units and the totalizer units are pre-set at the factory and must be the same.

### Screens:

The totalizer display has three screens which are accessed by pressing the button circled in the photo below:



**Screen 1** (start-up screen shown in photo above): Flow units are shown together with the actual flow

**Screen 2:** Totalized flow in the same units as Screen 1 above

**Screen 3:** Actual flow is shown together with the total flow

### Totalizer:

A total of 8 digits can be shown by the totalizer ranging from .0000001 to 99999999. The decimal point will automatically shift position as the total increases. Upon reaching the maximum count (99999999), the totalizer will “roll-over”--be cleared and begin counting from zero again.

The totalizer may be cleared by going to screen 2 or 3 and then pressing the button for more than 5 seconds. The clearing of the totalizer can be observed on the screen.

The total count is saved in non-volatile memory every 5 minutes. If the unit is switched off within 5 minutes from power-up then no total will be saved and the previous total will be shown at the next power-up.

*Caution:* Due to the combination of the hardware/LCD, it may happen that during power up the screen remains blank. If this occurs, please turn the unit off and then back on again



Caution!  
It is important that this transducer be serviced and/or calibrated by qualified personnel.

## Chapter 4 Maintenance and Repair

Top-Trak<sup>™</sup> transducers essentially require no scheduled maintenance other than periodic flow path cleaning if the gas is dirty. If an in-line filter is used, the filtering element should be periodically replaced or ultrasonically cleaned.

**CAUTION:** If the laminar flow element is removed from any Top-Trak<sup>™</sup> flow meter, re-calibration will be required to return the instrument to original accuracy.

Calibration of Sierra Instruments flow meters and controllers requires a calibrating standard of at least equal accuracy and preferably an order of magnitude better than the transducer, and a skilled factory technician familiar with the Top-Trak. It is recommended that Top-Trak meters be returned to the factory for annual evaluation and calibration.

Included in this chapter are general instructions for:

- Transducer Cleaning Instructions .....page 4-1
- Transducer Calibration .....page 4-9
- Transducer Troubleshooting ..... page 4-11
- Returning Equipment to the Factory ..... page 4-12

### Transducer Cleaning

Due to transducer design variations, separate cleaning instructions are given in this chapter for each of the following models:

- Model 822/824 with nylon flow body
- Model 826/827 with aluminum flow body
- Model 822-S/824-S with stainless steel flow body

When toxic or corrosive gases are used, the transducer must be thoroughly purged with inert dry gas before disconnecting from the gas line. Transducers used with toxic or corrosive gases **SHOULD NOT BE** returned to the factory since they constitute a safety hazard. Contact the factory with specific questions.

## Flow Path Cleaning Model 822/824

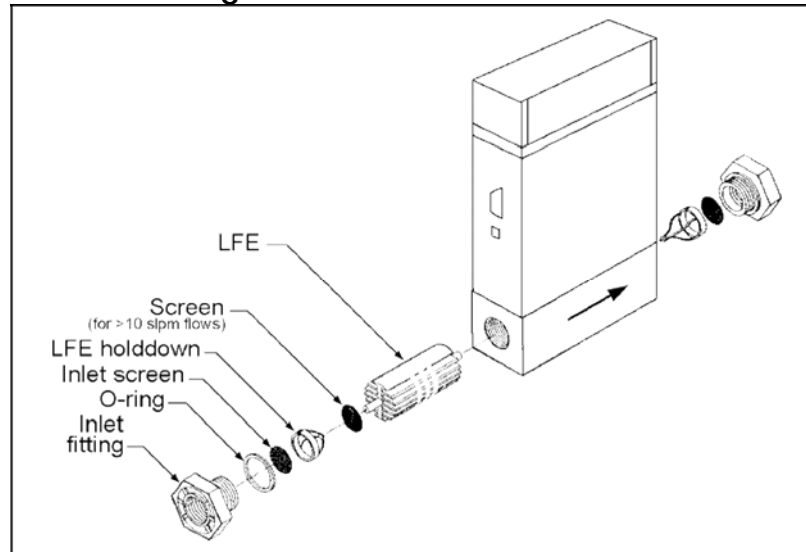

Figure 4-1. Model 822/824 Flow Components

### *Inlet and Outlet Screens*



**Caution!**

When using toxic or corrosive gases, purge the unit thoroughly with inert dry gas before disconnecting from the gas line.

1. Remove the transducer from the system.
2. Remove inlet and outlet fittings.
3. Pull out the laminar flow element (LFE) holddowns.
4. Replace or clean the inlet and outlet screens.
5. Re-assemble components. When the transducer is installed in the system, leak test the connection.
6. To be within the original accuracy, calibrate the transducer (see page 4-9).





**Caution!** Removing the LFE from the meter will change your calibration. Do not remove the LFE unless you are prepared to re-calibrate the instrument

### *Laminar Flow Element*

The laminar flow element (LFE) is a precision flow divider which diverts a preset amount of flow through the sensor tube. The particular LFE used depends on the gas and flow range of the instrument. To clean or inspect the LFE:

1. Remove the transducer from the system.
2. Remove the inlet and outlet fittings and inlet screen.
3. The LFE has a slightly tapered shape with the larger diameter on the upstream (inlet) side. To remove, use a blunt object which does not mar the flow channels to push the LFE from the outlet side to the inlet side. A 3/8-inch (9 mm) nut driver works well.
4. Clean the LFE using an alcohol-based solvent. Make sure to carefully clean all active flow channels in the LFE.
5. Re-install the LFE making sure to press it in the correct distance as shown below.
6. Re-assemble remaining components. When the transducer is installed in the system, leak test the connection. Re-zero the transducer (see Chapter 3).
7. Calibrate the instrument (see page 4-9).

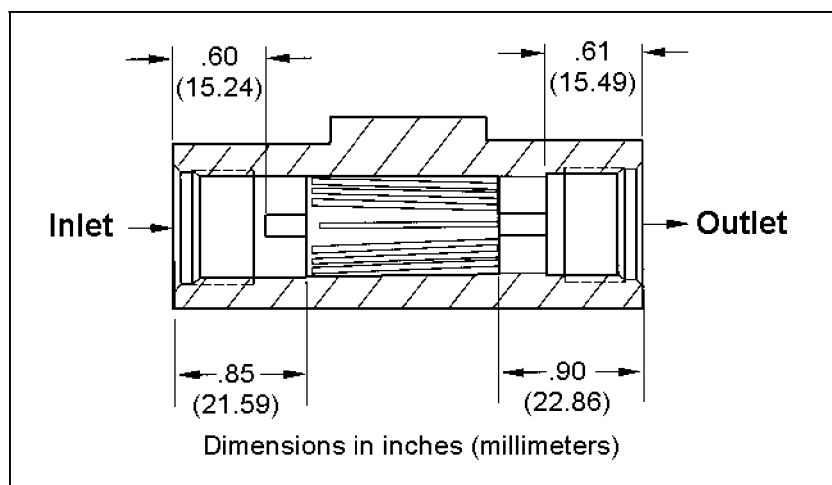

*Figure 4-2. Correct LFE Position*

## Flow Path Cleaning Model 826/827

### *Laminar Flow Element*



**Caution!** Removing the LFE from the meter will change your calibration. Do not remove the LFE unless you are prepared to re-calibrate the instrument

The laminar flow element (LFE) is a precision flow divider which diverts a preset amount of flow through the sensor tube. The particular LFE used depends on the gas and flow range of the instrument. To clean or inspect the LFE:

1. Remove the transducer from the system.
2. Remove the 6-32 hex nuts and washers. Remove the end caps. Note the position of the three (3) LFE elements.
  3. To remove the LFE, use a blunt object which does not mar the flow channels to push the LFE from the flow body.
  4. Clean the LFE using a suitable solvent. Make sure to carefully clean all active flow channels in the LFE.
  5. Re-install the LFE making sure to position it with both ends even with the transducer flow body.
  6. Re-assemble remaining components. When the transducer is installed in the system, leak test the connection. Re-zero the transducer (see Chapter 3).

7. Perform a calibration (see page 4-9).

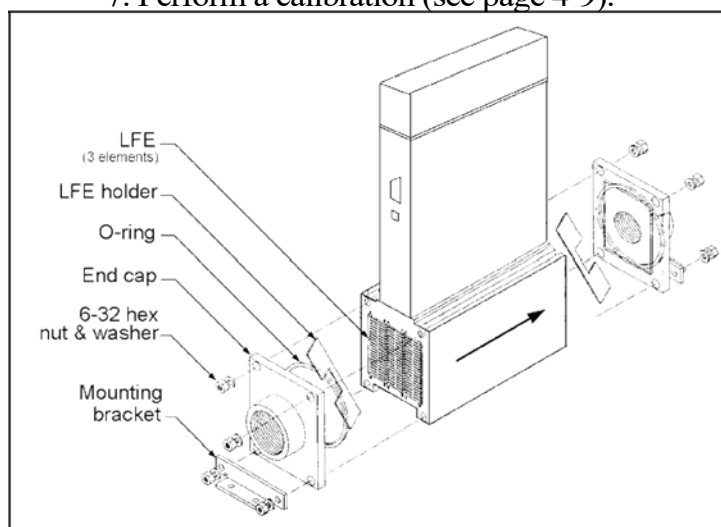

*Figure 4-3. Model 826/827 Flow Components*

## Flow Path Cleaning Model 822-S/824-S

### *Laminar Flow Element*

The laminar flow element (LFE) is a precision flow divider which diverts a preset amount of flow through the sensor tube. The LFE is made of precision machined 316 stainless steel. The particular LFE used depends on the gas and flow range of the instrument. Should the LFE require cleaning or inspection due to deposition, use the appropriate cleaning procedure which is specific to flow body size.

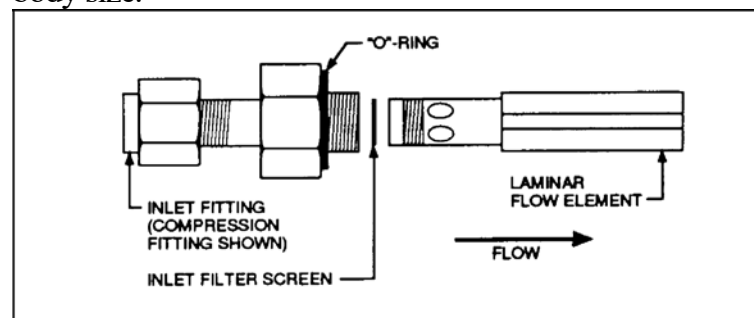

Figure 4-4. Low Flow Transducer LFE Cleaning

#### Low Flow Transducers:

The LFE is accessed by unscrewing the main inlet fitting and removing it from the flow body. The LFE is screwed into the inlet fitting, which has been specially machined for this purpose. To access the components:



**Caution!** Removing the LFE from the meter will change your calibration. Do not remove the LFE unless you are prepared to re-calibrate the instrument

1. Remove the transducer from the system.
2. The inlet filter screen is held in place in the inlet fitting by the LFE. Disassemble by holding the fitting steady with a wrench and unscrewing the LFE with a medium flat-tipped screwdriver.
3. Remove the LFE assembly taking care not to bend the inlet screen. Inspect the sealing O-ring and replace if necessary. Inspect the inlet screen and replace if corroded or damaged. Light to medium particulate contamination can be cleaned by back washing with a suitable solvent. Air dry thoroughly.

4. Inspect the LFE for damage and replace if necessary. Remember that removal or replacement of the LFE or inlet screen requires transducer re-calibration.
5. Re-assemble components. When the transducer is installed in the system, leak test the connection. Re-zero the transducer (see Chapter 3).
6. To be within the original accuracy, calibrate the transducer (see page 4-9).

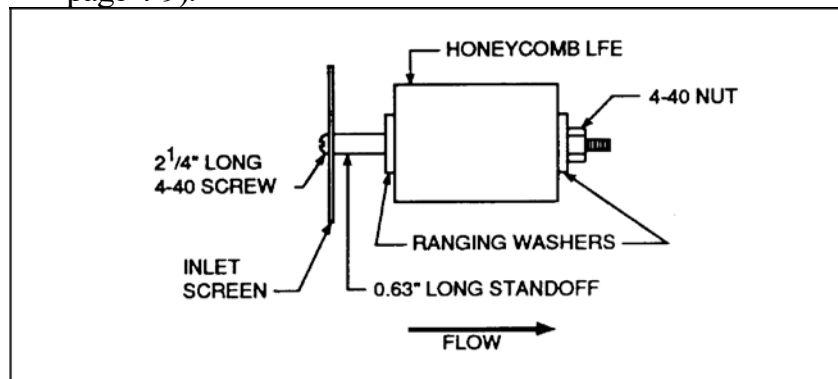

Figure 4-5. Medium Flow Transducer LFE Cleaning



**Caution!** Removing the LFE from the meter will change your calibration. Do not remove the LFE unless you are prepared to re-calibrate the instrument

### Medium Flow Transducers:

In the medium flow body, the LFE assembly consists of the honeycomb laminar flow element, inlet screen, 0.63 inch long standoff, two ranging washers, 2-1¼ inch long 4-40 screw and 4-40 nut. Range changes in the honeycomb element are made with various diameter ranging washers. To access the components:

1. Remove the unit from the system.
2. Access the LFE by unscrewing the four 10-32 socket head cap screws from the inlet side of the flow body and remove the inlet end cap. (Note the position of the screws, one has a shorter length.)
3. Remove the LFE assembly taking care not to bend the inlet screen. Inspect the sealing O-ring and replace if necessary. Inspect the inlet screen and replace if corroded or damaged. Light to medium particulate contamination can be cleaned by back washing with a suitable solvent. Air dry thoroughly.

4. Inspect the honeycomb element for damage and replace if necessary. Replacement of the LFE or inlet screen requires transducer re-calibration.
5. Re-assemble components. When the transducer is installed in the system, leak test the connection.
6. To be within the original accuracy, calibrate the transducer (see page 4-9).

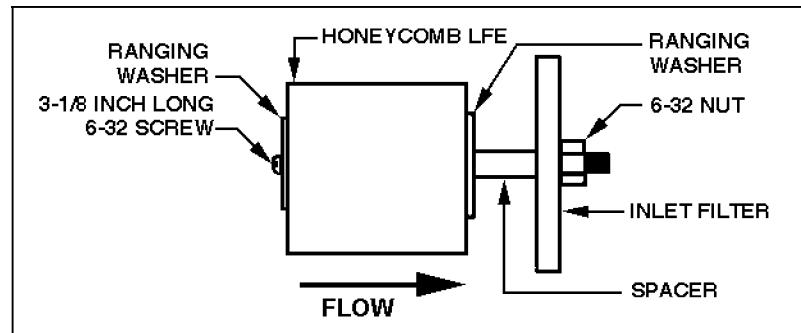

Figure 4-6. High Flow Transducer LFE Cleaning



**Caution!** Removing the LFE from the meter will change your calibration. Do not remove the LFE unless you are prepared to re-calibrate the instrument

### High Flow Transducers:

The high flow LFE is similar to the honeycomb element used in the medium flow body but larger in diameter. The high flow body consists of four parts: inlet tube, inlet cap, main flow body and end cap. The inlet tube is only removed to inspect and replace the sealing O-ring between the inlet tube and inlet cap. To access the components:

1. Remove the unit from the system.
2. To remove the inlet screen, remove the four 1/4-28 socket head cap screws on the inlet side of the flow body and separate the inlet cap from the main flow body.
3. Inspect the inlet screen for damage and corrosion and replace if necessary. Light to medium particulate contamination can be cleaned by back washing with a suitable solvent. Air dry thoroughly.
4. Inspect the sealing O-ring for damage and replace if necessary. The inlet screen is mounted with the fine mesh side facing the inlet.
5. To remove the LFE loosen and remove the four threaded rods holding the end cap to the main flow body. Separate the end cap from the main flow body and remove the LFE assembly. The LFE

assembly consists of: 6-32 x 3/8 inch long screw, a #6 washer, two ranging washers, honeycomb laminar flow element, LFE, spacer, inlet filter, and 6-32 nut.

6. Inspect the honeycomb element for damage and replace if necessary. Replacement of the LFE or inlet screen requires transducer re-calibration.
7. Re-assemble components. When the transducer is installed in the system, leak test the connection.
8. To be within the original accuracy, calibrate the transducer (see page 4-9).

### *Sensor Cleaning and Inspection*

Due to sensor design variations, the following sensor cleaning instructions are for Model 822-S/824-S *only*. All other transducer models must be returned to the factory.

Sensor cleaning is accomplished by simply rodding out the sensor with the Sensor Cleaning Stylette, part number "CKO" available from Sierra. A 0.028 inch diameter piano wire may also be used.



**Caution!** When using toxic or corrosive gases, purge the unit thoroughly with inert dry gas before disconnecting from the gas line.

To access the sensor for inspection or cleaning:

1. Remove the transducer from the system. Remove the two socket head access port plugs with a 1/4-inch Allen wrench. Visually inspect the sensing ports and sensor.

1. Use a hemostat or tweezers to push the cleaning wire into the downstream opening of the sensor tube. Do not force the cleaning wire, move it back and forth—DO NOT TWIST OR ROTATE.

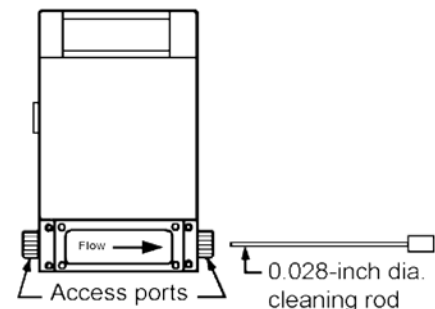

2. Flush the sensor tube with a non-residuous solvent compatible with the O-ring material. In cases where solids are deposited in sensor, units should be returned to factory for complete cleaning and re-calibration.

3. Blow dry all parts with dry nitrogen and re-assemble. When the transducer is installed in the system, leak test the connection. Re-zero the transducer (see Chapter 3).



Caution!  
It is important that this  
transducer be calibrated  
only by qualified personnel.

## Transducer Calibration

Calibration of Sierra's flow meters requires a calibration standard of at least four times the accuracy of the transducer. Sierra's Cal-Bench Automated Primary Calibration System is the preferred method of calibration and is used at the factory for all calibrations from 10 sccm up to 50 slpm. Most calibrations can be performed with a digital voltmeter (DVM) or multimeter with 0.25% accuracy and four digits, dry nitrogen and the K-factor tables included in this manual. Flow meters require a metering valve for setting a constant flow rate.

The following procedures are offered as guidelines for calibration. It is always best to return the transducer to the factory for calibration. Calibration checks and minor adjustments to the zero and full scale are made via the access ports in the enclosure. If the linearity needs adjustment (when installing a different bypass to change the range) skip Step 2 and Step 3. If linearity does not need adjustment, complete only Steps 1 through 3.

### Step 1. Warm Up

Plug in the unit to be calibrated and allow at least 30 minutes warm up time before attempting any adjustments.

### Step 2. Zero Adjust

Slide open the zero and span access doors. Connect a DVM or multimeter to the transducer output pins. Adjust the zero potentiometer for 0.0 volts (4 mA) at zero flow.

### Step 3. Check Full Scale

Generate full scale flow using a metering valve in-line with the unit under test. Compare the indicated flow rate with the flow standard reading. If they agree to within  $\pm 10\%$ , adjust the span potentiometer for exact agreement. If the readings do not agree within  $\pm 10\%$ , attempt to determine the cause of disagreement. Possibilities are:

- leaks in the system or in the transducer
- wrong or improper use of K-factor
- wrong or improper correction for temperature and pressure
- partially clogged or dirty sensor tube

- replacement of components in the flow path do not exactly match the original parts

This completes transducer calibration. To adjust linearity, continue with Step 4.

#### Step 4. Adjusting Linearity (see Figure 4-7)

First gain access to the printed circuit board inside the enclosure:

1. For units with the digital display, carefully rotate the display until it hits the top plate. Slide the display's two side panels up and remove. Move the display aside taking care not to damage the connecting cable.
2. Remove the two Phillips head screws from the top of the transducer enclosure. Remove the two Phillips head screws from the back of the transducer enclosure. Pull the enclosure panels off.
3. Orient the transducer with the component side of the circuit board facing you. Plug in the transducer and allow to warm up for at least 30 minutes.

#### Step 5. Zero Adjust

Connect a DVM to the transducer output pins. Adjust the zero potentiometer for 0.0 volts (4 mA) at zero flow.

#### Step 6. Calibrate 25%

Use the calibration standard to set a flow rate of 25% of full scale. Adjust the span potentiometer R21 for 1.25 volts (8 mA) at the output of the transducer.

#### Step 7. Calibrate 50%

Increase the flow rate to 50% of full scale. If the output is within +0.05 V (0.2 mA), no adjustment is necessary. If the output is beyond these limits, install a jumper block at J1 in the appropriate position (see Figure 4-7). Adjust R25 for the proper reading.

#### Step 8. Calibrate 75% and 100%

Set the flow to 75% of full scale. If the output is outside the limits set in Step 7, install a jumper block in J2 in the appropriate position. Adjust R27 for the correct reading. Repeat this procedure for 100% flow using R29. Repeat Steps 6 through 8 at least one more time.



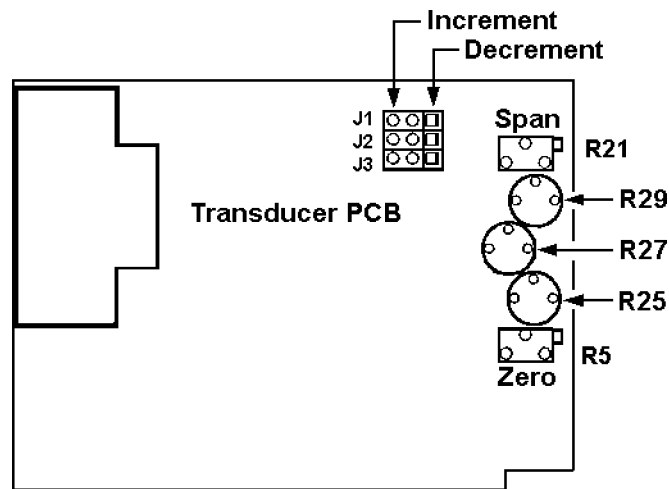

Figure 4-7. Printed Circuit Board Component Locations

## Transducer Troubleshooting

When you suspect that the transducer is not operating correctly, there are a few simple checks that can be made before taking the unit out of service:

1. Make certain that there are no leaks in the gas line.
2. Check that all cables are connected and are in good condition.
3. Verify that the power supply is in the correct range and properly connected to the transducer.
4. Double check connector pin outs when replacing another manufacturer's transducer.

This information is provided to help locate the cause of a transducer failure. It is not intended to be an all inclusive repair guide. For most repairs, the unit should be returned to the factory for service.

<b>Problem</b>	<b>Possible Cause</b>	<b>Solution</b>
<b>No output</b>	No power Inlet filter screen clogged Clogged sensor PCB defective	Plug in power supply Clean or replace screen Return to factory for cleaning* Return to factory for repair
<b>Unit will not zero</b>	Gas leak Application requires high pressure and non-horizontal mounting PCB defective	Find and correct leaks Re-zero transducer (see Chapter 3) Return to factory for repair
<b>Reads full scale with no flow</b>	Gas leak Liquid present in system Defective sensor	Find and correct leaks Check for liquid in flow path Return to factory for repair
<b>Output too high</b>	Incorrect calibration or K-factor Liquid present in system Defective sensor	Correct calibration/k-factor Check for liquid in flow path Return to factory for repair
<b>Out of calibration</b>	Dirty or clogged sensor Change in composition of gas Gas leak LFE dirty Inlet filter screen clogged Incorrect inlet conditions (1/2-inch size models) PCB defective	Return to factory for cleaning* See K-factory tables Find and correct leaks Clean LFE Clean or replace screen Re-plumb transducer correctly (See Chapter 2) Return to factory for repair
*Model 822-S/824-S see sensor cleaning instructions		

## Returning Equipment to the Factory

### *Factory Calibration—All Models*

Sierra Instruments maintains a fully-equipped calibration laboratory. All measuring and test equipment used in the calibration of Sierra transducers are traceable to NIST Standards. Sierra is ISO-9001 registered and conforms to the requirements of ANSI/NCSSL-Z540 and ISO/IEC Guide 25.

### *Instructions for Returning Your Instrument for Service*

The following information will help you return your instrument to Sierra Instruments' Factory Service Center and will ensure that your order is processed promptly. Prices may vary depending on the flow range, type of gas and operating pressure of your unit. To request a rough estimate of the pricing, contact your local Sierra Instruments distributor or contact one of our offices directly. A detailed quote will be provided following a full evaluation of your instrument.

### *Please follow these easy steps to return your instrument for factory service:*

1. Obtain a Return Materials Authorization (RMA) number from the Sierra Instruments website at <http://www.sierrainstruments.com/rma/login.php>
2. If you require service beyond calibration, but do not know which service(s) will be required, describe the symptoms as accurately as possible on the RMA form..
3. Pack your instrument carefully. Use the original packaging and foam or bubble wrap (packing peanuts NOT recommended) and include a copy of the RMA form (complete with Sierra supplied RMA number) with the unit(s).
4. Ship the unit(s) to the following address:



**Caution!**

Always fully neutralize any toxic gas trapped inside the instrument before removing it from the gas line.

**Sierra Instruments, Inc.  
Attention: Factory Service Center  
5 Harris Court, Building L  
Monterey, CA 93940 USA**

**CUSTOMER SERVICE AND SUPPORT INFORMATION:**

**Email Technical Support:** [service@sierrainstruments.com](mailto:service@sierrainstruments.com)

**Email Sales:** [sales@sierrainstruments.com](mailto:sales@sierrainstruments.com)

**FACTORY USA (Monterey, California)**

TOLL FREE: 800-866-0200

PHONE: 831-373-0200

FAX: 831-373-4402

**EMAIL:** [service@sierrainstruments.com](mailto:service@sierrainstruments.com)

**European Sales & Service Center (Egmond a/d Hoef, Netherlands)**

PHONE: +31 72 5071400

FAX: +31 72 5071401

**EMAIL:** [service@sierra-instruments.nl](mailto:service@sierra-instruments.nl)

**Asia Sales & Service Center (Shanghai, Peoples Republic of China)**

PHONE: + 86 21 5879 8521

FAX: +86 21 5879 85861

**SAFETY NOTE ABOUT PURGING**

**WARNING:** When toxic or corrosive gases are used, purge unit thoroughly with inert dry gas before disconnecting from the gas line to prevent personnel from being injured when coming in contact with the instrument. If an instrument used with a toxic or corrosive gas is returned to the factory, a Material Safety Data Sheet (MSDS) must be enclosed & attached to the outside of the box to alert Sierra personnel of the potential hazard. Also, make sure the inlet & outlet are solidly plugged off.



## Appendix A Conversion Formulas and Gas Tables

### *Conversion of Flow Rate to Other T and P Conditions*

The flow rate of your transducer is referenced to certain “standard” conditions of temperature and pressure. Unless otherwise specified in your order, these standard conditions are 21 °C (70°F) and 760 mm of mercury (1 atmosphere). If you wish to convert to other “standard” conditions or to find the “actual” conditions in the pipe where your instrument is installed, use the following relationship:

$$Q_2 = \frac{P_1}{P_2} \frac{T_2}{T_1} Q_1 \quad (1)$$

( )<sub>1</sub> = The standard conditions under which your instrument was calibrated,

( )<sub>2</sub> = The new standard conditions or the actual temperature and pressure conditions in the pipe,

Q<sub>1</sub> = The gas mass flow rate referenced to the calibrated standard conditions (sccm or slm),

Q<sub>2</sub> = The gas mass flow rate referenced to the new standard or actual conditions (sccm or slm—“S” means “standard,” accm or alm—“A” means “actual”),

P = Absolute pressure (kg/cm<sup>2</sup> or psia), and

T = Absolute temperature (°K or °R) (°K = °C + 273, °R = °F + 460).

#### Example 1: Changing “Standard” Conditions

If your transducer has a flow rate reading of 10.00 slm and was calibrated at standard conditions of 70°F (21°C) and 1 atmosphere (14.7 psia), and if you wish to convert this reading to standard conditions of 32°F (0°C) and 1 atmosphere, then you would use Equation (1) as follows:

$$Q_2 = \frac{14.7}{14.7} \frac{460 + 32}{460 + 70} (10.0) = 9.28 \text{ slm}$$

The flow rate referenced to 0°C will be approximately 7% lower than when referenced to standard conditions of 21 °C.

**Example 2: Finding the “Actual” Flow Rate**

If the flow rate and calibrated standard conditions are as given in Example 1 and you wish to find the actual flow rate at 100°F and 30 psig, then you would use Equation (1) as follows:

$$Q_2 = \frac{14.7}{14.7 + 30} \left( \frac{460 + 100}{460 + 70} \right) = 3.47 \text{ l m}$$

***Calculating For a Single Gas***

The following tables provide K-factors and thermodynamic properties of gases commonly used with mass flow meters and controllers. The purpose of these tables is two-fold:

1. Calibrating an “actual” gas with a reference gas. This is particularly useful if the actual gas is not a common gas or if it is toxic, flammable, corrosive, etc.
2. Interpreting the reading of a flow meter or flow controller which has been calibrated with a gas other than the actual gas.

In applying the tables, the following fundamental relationship is used:

$$Q_1/Q_2 = K_1/K_2 \quad (1)$$

Where:

Q = The volumetric flow rate of the gas referenced to normal conditions of 0°C and 760 mm Hg (sccm or slm),

K = The K-factor defined in equation (6),

( )<sub>1</sub> = Refers to the “actual” gas, and

( )<sub>2</sub> = Refers to the “reference” gas.

The K-factor is derived from the first law of thermodynamics applied to the sensor tube, as described in Chapter 1:

$$H = \mu C_p T \quad (2)$$

Where:

$H$  = The constant amount of heat applied to the sensor tube,

$\mu$  = The mass flow rate of the gas (gm/min)

$C_p$  = The coefficient of specific heat of the gas (Cal/gm);  
 $C_p$  is given in the Table (at 0°C),

$\Delta T$  = The temperature difference between the downstream and upstream coils, and

$N$  = A correction factor for the molecular structure of the gas given by the following table:

Number of Atoms in the Gas Molecule	$N$
Monatomic	1.040
Diatomic	1.000
Triatomic	0.941
Polyatomic	0.880

The mass flow rate,  $\mu$ , can also be written as:

$$\mu = \rho Q \quad (3)$$

Where:

$\rho$  = The gas mass density at standard conditions (g/l);  $\rho$  is given in the tables (at 0°C, 760 mm Hg).

Furthermore, the temperature difference,  $\Delta T$ , is proportional to the output voltage,  $E$ , of the mass flow meter, or

$$\Delta T = aE \quad (4)$$

where:

$a$  = a constant.

If we combine equations (3) and (4), insert them into equation (2), and solve for  $Q$ , we get

$$Q = (bN/\rho C_p) \quad (5)$$

where:

$b = H/aE$  = a constant if the output voltage is constant.

For our purposes, we want the ratio of the flow rate,  $Q_1$ , for an actual gas to the flow rate of a reference gas,  $Q_2$ , which will produce the same output voltage in a particular mass flow meter or controller. We get this by combining equations (1) and (5):

$$Q_1/Q_2 = K_1/K_2 = (N_1/\rho_1 C_{p1})/(N_2/\rho_2 C_{p2}) \quad (6)$$

Please note that the constant  $b$  cancels out. Equation (6) is the fundamental relationship used in the accompanying tables. For convenience, the tables give “relative”  $K$ -factors, which are the ratios  $K_1/K_2$ , instead of the  $K$ -factors themselves. In the tables, the relative  $K$ -factor is  $K_{\text{actual}}/K_{N_2}$  where the reference gas is the commonly used gas, nitrogen ( $N_2$ ). The remaining columns give  $C_p$  and  $\rho$ , enabling you to calculate  $K_1/K_2$  directly using Equation (6). In some instances,  $K_1/K_2$  from the tables may be different from that which you calculate directly. The value from the tables is preferred because in many cases it was obtained by experiment. Sierra calibrates every transducer with primary standards using the actual gas or a molecular equivalent reference gas. The calibration certificate accompanying the transducer cites the reference gas used.

#### Example 1:

A transducer is calibrated for nitrogen ( $N_2$ ), and the flow rate is 1000 sccm for a 5.000 VDC output signal. The flow rate for carbon dioxide at a 5.000 VDC output is:

$$Q_{CO_2}/Q_{N_2} = K_{CO_2}/K_{N_2}, \text{ or}$$

$$Q_{CO_2} = (0.74/1.000)1000 = 740 \text{ sccm}$$

#### Example 2:

A transducer is calibrated for hydrogen ( $H_2$ ), and the flow rate is 100 sccm for a 5.000 VDC output signal. The flow rate for nitrous oxide ( $N_2O$ ) is found as follows:

$$Q_{N_2O}/Q_{H_2} = K_{N_2O}/K_{H_2}, \text{ or}$$

$$Q_{N_2O} = (0.71/1.01) 100 = 70.3 \text{ sccm}$$

*Note that the  $K$ -factors relative to nitrogen must be used in each case.*

#### Example 3:

We want a transducer to be calibrated for use with dichlorosilane ( $SiH_2Cl_2$ ) at a 100 sccm full scale flow. We wish to use the preferred reference gas Freon-14 ( $CF_4$ ). What flow of  $CF_4$  must we generate to do the calibration?

$$Q_{SiH_2Cl_2}/Q_{CF_4} = K_{SiH_2Cl_2}/K_{CF_4}$$

$$100/Q_{CF_4} = 0.869$$

$$Q_{CF_4} = 100/0.869 = 115 \text{ sccm}$$



### *Calculating Dual Gas Mixtures*

Equation (6) is used for gas mixtures, but we must calculate  $N/p C_p$  for the mixture. The equivalent values of  $p$ ,  $C_p$ , and  $N$  for a dual gas mixture are given as follows:

The equivalent gas density is:

$$P = (m_1 / m_T) P_1 + (m_2 / m_T) P_2$$

Where:

$$\dot{M}_1 = \dot{m}_1 + \dot{m}_2 = \text{Total mass flow rate (g/min).}$$

$( )_1$  = Refers to gas #1, and

$( )_2$  = Refers to gas #2

The equivalent specific heat is:

$$C_p = F_1 C_{p1} + F_2 C_{p2}$$

Where:

$$F_1 = (m_1 P_1) / (m_T P)$$

$$F_2 = (m_2 P_2) / (m_T P)$$

The equivalent value of  $N$  is:

$$N = (M_1 / m_T) N_1 + (m_2 / m_T) N_2$$

The equivalency relationships for  $p$ ,  $C_p$ , and  $N$  for mixtures of more than two gases have a form similar to the dual-gas relationship given above.

#### **IMPORTANT NOTE ABOUT K-FACTORS:**

Please note that if you have a transducer calibrated for a gas such as methane and wish to use the K-factors to measure a gas such as air, that the inaccuracy of the measurement can range from  $\pm 5$  to 10%. The use of K-factors is, at best, only a rough approximation and should not be used in applications that require a better than  $\pm 5$  to 10% accuracy.

It should also be noted that certain gases, in similar "families," will work exceptionally well with K-factors; however, those instances are only true when similar thermal properties of the gas are present.

Actual Gas	Chemical Symbol	K-factor Relative N2	Cp (Cal/g)	Density (g/l) @ 0°C	Elastomer*		Nylon Compatible	Corrosive Gas Limited Warranty
					O-ring*	Valve Seat		
Acetylene	C <sub>2</sub> H <sub>2</sub>	0.58	0.4036	1.162	Viton®	Viton®		
Air		1	0.24	1.293	Viton®	Viton®		
Allene (Propadiene)	C <sub>3</sub> H <sub>4</sub>	0.43	0.352	1.787		KR		
Ammonia	NH <sub>3</sub>	0.73	0.492	0.76	NEO	KR		
Argon	Ar	1.45	0.1244	1.782	Viton®	Viton®		
Arsine	AsH <sub>3</sub>	0.67	0.1167	3.478	Viton®	KR		
Boron Trichloride	BCl <sub>3</sub>	0.41	0.1279	5.227	KR	KR		YES
Boron Trifluoride	BF <sub>3</sub>	0.51	0.1778	3.025	Viton®	KR		
Boron Tribromide	Br <sub>3</sub>	0.38	0.0647	11.18	Viton®	KR		
Bromine	Br <sub>2</sub>	0.81	0.0539	7.13	Viton®	Viton®	NO	
Bromine Pentafluoride	BrF <sub>5</sub>	0.26	0.1369	7.803	Viton®	KR	NO	
Bromine Trifluoride	BrF <sub>3</sub>	0.38	0.1161	6.108	Viton®	KR	NO	
Bromotrifluoromethane (Freon-13 B1)	CBrF <sub>3</sub>	0.37	0.1113	6.644	Viton®	Viton®		
1,3-Butadiene	C <sub>4</sub> H <sub>6</sub>	0.32	0.3514	2.413	Viton®	Viton®		
Butane	C <sub>4</sub> H <sub>10</sub>	0.26	0.4007	2.593	Viton®	Viton®		
1-Butane	C <sub>4</sub> H <sub>8</sub>	0.3	0.3648	2.503	Viton®	Viton®		
2-Butane	C <sub>4</sub> H <sub>8</sub> CIS	0.324	0.336	2.503	Viton®	Viton®		
2-Butane	C <sub>4</sub> H <sub>8</sub> TRANS	0.291	0.374	2.503	Viton®	Viton®		
Carbon Dioxide	CO <sub>2</sub>	0.74	0.2016	1.964	Viton®	Viton®		
Carbon Disulfide	CS <sub>2</sub>	0.6	0.1428	3.397	Viton®	Viton®		
Carbon Monoxide	CO	1	0.2488	1.25	Viton®	Viton®		
Carbon Tetrachloride	CCl <sub>4</sub>	0.31	0.1655	6.86	Viton®	KR	NO	
Carbon Tetra fluoride (Freon-14)	CF <sub>4</sub>	0.42	0.1654	3.926	Viton®	Viton®		
Carbonyl Fluoride	COF <sub>2</sub>	0.54	0.171	2.945	Viton®	Viton®		
Carbonyl Sulfide	COS	0.66	0.1651	2.68	Viton®	Viton®		
Chlorine	CL <sub>2</sub>	0.86	0.114	3.163	Viton®	KR	NO	YES
Chlorine Trifluoride	ClF <sub>3</sub>	0.4	0.165	4.125	Viton®	KR		
Chlorodifluoromethane (Freon-22)	CHClF <sub>2</sub>	0.46	0.1544	3.858	Viton®	KR		
Chloroform	CHCl <sub>3</sub>	0.39	0.1309	5.326	Viton®	KR		
Chloropentafluoroethane (Freon-115)	C <sub>2</sub> ClF <sub>5</sub>	0.24	0.164	6.892	Viton®	KR		
Chlorotrifluoromethane (Freon-13)	CClF <sub>3</sub>	0.38	0.153	4.66	Viton®	KR		

\* If no O-ring material is specified then O-ring to be used is Viton

Actual Gas	Chemical Symbol	K-factor Relative N2	Cp (Cal/g)	Density (g/l) @ 0°C	Elastomer*		Nylon Compatible	Corrosive Gas Limited Warranty
					O-ring	Valve Seat		
Cyanogen	C <sub>2</sub> N <sub>2</sub>	0.61	0.2613	2.322	Viton®	KR		
Cyanogen Chloride	CICN	0.61	0.1739	2.742	KR	KR		800 Only
Cychlopropane	C <sub>3</sub> H <sub>5</sub>	0.46	0.3177	1.877	Viton®	KR		
Deuterium	D <sub>2</sub>	1	0.1722	1.799	Viton®			
Diborane	B <sub>2</sub> H <sub>6</sub>	0.44	0.508	1.235	Viton®	KR		
Dibromodifluoromethane	CBr <sub>2</sub> F <sub>2</sub>	0.19	0.15	ATEX	Viton®	KR		
Dibromomethane		0.47	0.075	7.76	Viton®	KR		
Dichlorodifluoromethane	CCl <sub>2</sub> F <sub>2</sub>	0.35	0.1432	5.395	Viton®	KR		
(Freon-12)								
Dichlorofluoromethane	CHCl <sub>2</sub> F	0.42	0.14	4.952	Viton®	KR		
(Freon-21)								
Dichloromethylsilane	(CH <sub>3</sub> ) <sub>2</sub> SiCl <sub>2</sub>	0.25	0.1882	5.758	Viton®	KR		
Dichlorosilane	SiH <sub>2</sub> Cl <sub>2</sub>	0.4	0.15	4.506	Viton®	KR		
Dichlorotetrafluoroethane	C <sub>2</sub> Cl <sub>2</sub> F <sub>4</sub>	0.22	0.1604	7.626	Viton®	KR		
(Freon-114)								
1,1-Difluoroethylene	C <sub>2</sub> H <sub>2</sub> F <sub>2</sub>	0.43	0.224	2.857	Viton®	KR		
(Freon-1132A)								
Dimethylamine	(CH <sub>3</sub> ) <sub>2</sub> NH	0.37	0.366	2.011	Viton®	KR		
Dimethyl Ether	(CH <sub>3</sub> ) <sub>2</sub> O	0.39	0.3414	2.055	Viton®	KR		
2,2-Dimethylpropane	C <sub>3</sub> H <sub>12</sub>	0.22	0.3914	3.219	Viton®	KR		
Ethane	C <sub>2</sub> H <sub>6</sub>	0.5	0.4097	1.342	Viton®	Viton®	NO	
Ethanol	C <sub>2</sub> H <sub>6</sub> O	0.39	0.3395	2.055	Viton®	KR		
EthylAcetylene	C <sub>4</sub> H <sub>6</sub>	0.32	0.3513	2.413	Viton®	KR		
Ethyl Chloride	C <sub>2</sub> H <sub>5</sub> Cl	0.39	0.244	2.879	Viton®	KR		
Ethylene	C <sub>2</sub> H <sub>4</sub>	0.6	~.358	1.251	Viton®	Viton®		
Ethylene Oxide	C <sub>2</sub> H <sub>4</sub> O	0.52	0.268	1.965	KR	KR		
Fluorine	F <sub>2</sub>	0.98	0.1873	1.695	Viton®	KR		YES
Fluoroform (Freon-23)	CHF <sub>3</sub>	0.5	0.176	3.127	Viton®	KR	NO	
Freon-11	CCl <sub>3</sub> F	0.33	0.1357	6.129	Viton®	KR	NO	
Freon-12	CCl <sub>2</sub> F <sub>2</sub>	0.35	0.1432	5.395	Viton®	KR	NO	
Freon-13	CClF <sub>3</sub>	0.38	0.153	4.66	Viton®	KR	NO	
Freon-13	B1 CFrF <sub>3</sub>	0.37	0.1113	6.644	Viton®	KR	NO	
Freon-14	CF <sub>4</sub>	0.42	0.1654	3.926	Viton®	Viton®	NO	
Freon-21	CHCl <sub>2</sub> F	0.42	0.14	4.952	Viton®	KR	NO	
Freon-22	CHClF <sub>2</sub>	0.46	0.1544	3.858	Viton®	KR	NO	
Freon-113	CCl <sub>2</sub> FCClF <sub>2</sub>	0.2	0.161	8.36	Viton®	KR	NO	
Freon-114	C <sub>2</sub> Cl <sub>2</sub> F <sub>4</sub>	0.22	0.16	7.626	Viton®	KR	NO	
Freon-115	C <sub>2</sub> ClF <sub>5</sub>	0.24	0.164	6.892	Viton®	KR	NO	
Freon-C318	C <sub>4</sub> F <sub>8</sub>	0.17	0.185	8.397	NEO	NEO	NO	



Actual Gas	Chemical Symbol	K-factor Relative N2	Cp (Cal/g)	Density (g/l) @ 0°C	Elastomer*		Nylon Compatible	Corrosive Gas Limited Warranty
					O-ring	Valve Seat		
Germane	GeH <sub>4</sub>	0.57	0.1404	3.418	Viton®	Viton®		
Germanium Tetrachloride	GeCl <sub>4</sub>	0.27	0.1071	9.565	Viton®	KR		
Helium	He	1.454	1.241	0.1786	Viton®	Viton®		
Hexafluoroethane (Freon-116)	C <sub>2</sub> F <sub>6</sub>	0.24	0.1834	6.157	Viton®	KR	NO	
Hexane	C <sub>6</sub> H <sub>14</sub>	0.18	0.3968	3.845	Viton®	KR		
Hydrogen	H <sub>2</sub>	1.01	3.419	0.0899	Viton®	Viton®		
Hydrogen Bromide	HBr	1	0.0861	3.61	Viton®	KR		
Hydrogen Chloride	HCl	1	0.1912	1.627	KR	KR		YES
Hydrogen Cyanide	HCN	1.07	0.3171	1.206	Viton®	KR		
Hydrogen Fluoride	HF	1	0.3479	0.893	KR	KR		YES
Hydrogen Iodide	HI	1	0.0545	5.707	Viton®	KR		
Hydrogen Selenide	H <sub>2</sub> Se	0.79	0.1025	3.613	Viton®	KR		
Hydrogen Sulfide	H <sub>2</sub> S	0.8	0.2397	1.52	NEO	KR		
Iodine Pentafluoride	IF <sub>5</sub>	0.25	0.1108	9.9	Viton®	KR		
Isobutane	CH(CH <sub>3</sub> ) <sub>3</sub>	0.27	0.3872	2.593	Viton®	KR		
Isobutylene	C <sub>4</sub> H <sub>8</sub>	0.29	0.3701	2.503	Viton®	KR		
Krypton	Kr	1.453	0.0593	3.739	Viton®	Viton®		
Methane	CH <sub>4</sub>	0.72	0.5328	0.715	Viton®	Viton®		
Methanol	CH <sub>3</sub> OH	0.58	0.3274	1.429	Viton®	Viton®		
Methyl Acetylene	C <sub>3</sub> H <sub>4</sub>	0.43	0.3547	1.787	Viton®	KR		
Methyl Bromide	CH <sub>3</sub> Br	0.58	0.1106	4.236	Viton®	Viton®		
Methyl Chloride	CH <sub>3</sub> Cl	0.1926	2.253		Viton®	KR		
Methyl Fluoride	CH <sub>3</sub> F	0.68	0.3221	1.518	Viton®	KR		
Methyl Mercaptan	CH <sub>3</sub> SH	0.52	0.2459	2.146	Viton®	KR		
Methyl Trichlorosilane	(CH <sub>3</sub> ) SiCl <sub>3</sub>	0.25	0.164	6.669	Viton®	KR		
Molybdenum Hexafluoride	MoF <sub>6</sub>	0.21	0.1373	9.366	Viton®	KR		
Monoethylamine	C <sub>2</sub> H <sub>5</sub> NH <sub>2</sub>	0.35	0.387	2.011	Viton®	KR		
Monomethylamine	CH <sub>3</sub> NH <sub>2</sub>	0.51	0.4343	1.386	Viton®	KR		
Neon	NE	1.46	0.245	0.9	Viton®	Viton®		
Nitric Oxide	NO	0.99	0.2328	1.339	Viton®	Viton®	NO	
Nitrogen	N <sub>2</sub>	1	0.2485	1.25	Viton®	Viton®		
Nitrogen Dioxide	NO <sub>2</sub>	0.74	0.1933	2.052	KR	KR	NO	YES
Nitrogen Trifluoride	NF <sub>3</sub>	0.48	0.1797	3.168	Viton®	KR		
Nitrosyl Chloride	NOCl	0.61	0.1632	2.92	Viton®	KR		
Nitrous Oxide	N <sub>2</sub> O	0.71	0.2088	1.964	Viton®	Viton®		
Octafluorocyclobutane (Freon-C318)	C <sub>4</sub> F <sub>8</sub>	0.17	0.185	8.397	Viton®	KR		
Oxygen Difluoride	OF <sub>2</sub>	0.63	0.1917	2.406	Viton®	Viton®		
Oxygen	O <sub>2</sub>	1	0.2193	1.427	Viton®	Viton®		
Ozone	O <sub>3</sub>	0.446	0.3	2.144	Viton®	Viton®	NO	

Actual Gas	Chemical Symbol	K-factor Relative N2	Cp (Cal/g)	Density (g/l) @ 0°C	Elastomer*		Nylon Compatible	Corrosive Gas Limited Warranty
					O-ring	Valve Seat		
Pentaborane	B <sub>5</sub> H <sub>9</sub>	0.26	0.38	2.816	Viton®	KR		
Pentane	C <sub>5</sub> H <sub>12</sub>	0.21	0.398	3.219	Viton®	KR		
Perchloryl Fluoride	ClO <sub>3</sub> F	0.39	0.1514	4.571	Viton®	KR		
Perfluoropropane	C <sub>3</sub> F <sub>8</sub>	0.174	0.197	8.388	Viton®	KR		
Phosgene	COCl <sub>2</sub>	0.44	0.1394	4.418	Viton®	KR		
Phosphine	PH <sub>3</sub>	0.76	0.2374	1.517	Viton®	KR		
Phosphorous Oxychloride	POCl <sub>3</sub>	0.36	0.1324	6.843	Viton®	KR		
Phosphorous Pentafluoride	PF <sub>5</sub>	0.3	0.161	5.62	Viton®	KR		
Phosphorous Trichloride	PCl <sub>5</sub>	0.3	0.125	6.127	Viton®	KR		
Propane	C <sub>3</sub> H <sub>8</sub>	0.36	0.3885	1.967	Viton®	Viton®		
Propylene	C <sub>3</sub> H <sub>6</sub>	0.41	0.3541	1.877	Viton®	Viton®		
Silane	SiH <sub>4</sub>	0.6	0.3189	1.433	Viton®	KR		
Silicon Tetrachloride	SiCl <sub>4</sub>	0.28	0.127	7.58	Viton®	KR		
Silicon Tetrafluoride	SiF <sub>4</sub>	0.35	0.1691	4.643	Viton®	KR		
Sulfur Dioxide	SO <sub>2</sub>	0.69	0.1488	2.858	Viton®	KR		YES
Sulfur Hexafluoride	SF <sub>6</sub>	0.26	0.1592	6.516	Viton®	Viton®		
Sulfuryl Fluoride	SO <sub>2</sub> F <sub>2</sub>	0.39	0.1543	4.562	Viton®	KR		
Teos		0.09			KR	KR		YES
Tetrafluorohydrazine	N <sub>2</sub> F <sub>4</sub>	0.32	0.182	4.64	Viton®	KR		
Trichlorofluormethane (Freon-11)	CCl <sub>3</sub> F	0.33	0.1357	6.129	Viton®	KR		
Trichlorosilane	SiHCl <sub>3</sub>	0.33	0.138	6.043	Viton®	KR		
1,1,2-Trichloro-1,2,2	CCl <sub>2</sub> FCClF <sub>2</sub>	0.2	0.161	8.36	Viton®	KR		
Trifluoroethane (Freon-113)					Viton®	Viton®		
Trisobutyl Aluminum	(C <sub>4</sub> H <sub>9</sub> )Al	0.061	0.508	8.848	Viton®	KR		
Titanium Tetrachloride	TiCl <sub>4</sub>	0.27	0.12	8.465	Viton®	KR		
Trichloro Ethylene	C <sub>2</sub> HCl <sub>3</sub>	0.32	0.163	5.95	Viton®	KR		
Trimethylamine	(CH <sub>3</sub> ) <sub>3</sub> N	0.28	0.371	2.639	Viton®	KR		
Tungsten Hexafluoride	WF <sub>6</sub>	0.25	0.081	13.28	KR	Teflon		YES
Uranium Hexafluoride	UF <sub>6</sub>	0.2	0.0888	15.7	Viton®	KR		
Vinyl Bromide	CH <sub>2</sub> CHBr	0.46	0.1241	4.772	Viton®	KR		
Vinyl Chloride	CH <sub>2</sub> CHCl	0.48	0.12054	2.788	Viton®	KR		
Xenon	Xe	1.44	0.0378	5.858	Viton®	Viton®		

# Appendix B 822/824 Product Specifications

## DIMENSIONAL SPECIFICATIONS

Model 820—Side View

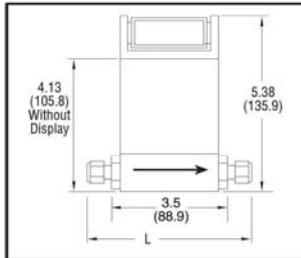

Model 820—Outlet View

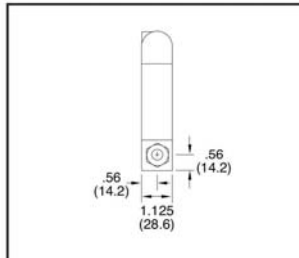

Model 820—Bottom View

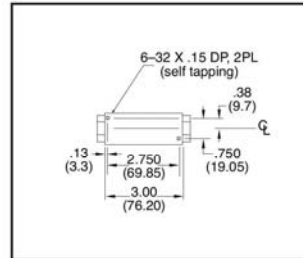

All dimensions are inches and in parentheses are millimeters. Certified drawings are available on request.

FITTING SIZE			
	1/8-inch Compression	1/4-inch Compression	1/4-inch NPT
Dim. L	5.51(140.0)	5.70(144.8)	3.50(88.9)

## Performance Specifications

### Accuracy

+/- 1.5% of Full Scale under calibration conditions including linearity over 15° to 25°C and 5 to 60 psia (0.3 to 4 bara).  
 If the meter is mounted with a vertical (up or down) flow path the following accuracy de-rating applies:  
 Notes: (1) Do not exceed 150 psig.  
 (2) Difference between inlet pressure and calibrated pressure. Do not exceed ± 10 psig.

OPERATING PRESSURE			
Inlet Pressure Deviation <sup>2</sup>	50 psig	100 psig	150 psig
+/- 1 psig	+/- 1.5% of Full Scale	+/- 1.5% of Full Scale	+/- 1.5% of Full Scale
+/- 5 psig	+/- 3.8% of Full Scale	+/- 4.5% of Full Scale	+/- 5.3% of Full Scale
+/- 10 psig	+/- 6% of Full Scale	+/- 7.5% of Full Scale	+/- 9% of Full Scale

### Repeatability

+/- 0.5% of Full Scale

### Temperature Coefficient

0.08% of Full Scale per °F (0.15% of Full Scale per °C), or better

### Pressure Coefficient

0.01% of Full Scale per psi (0.15% of Full Scale per bar), or better

### Response Time

.800 ms time constant; six seconds (typical) within +/- 2% of final value over 25 to 100% of Full Scale

### Gases

## OPERATING SPECIFICATIONS

Most gases; check compatibility with wetted materials; specify when ordering

### Mass Flow Rates

0 to 10 sccm up to 0 to 50 slpm; flow ranges specified are for an equivalent flow of nitrogen at 760 mm Hg and 21°C (70°F); other ranges in other units are available (e.g., scfh or nm<sup>3</sup>/h)

### Gas Pressure

150 psig (10 barg) maximum;  
 20 psig (1.4 barg) optimum

### Gas & Ambient Temperature

32 to 122°F (0 to 50°C)

### Leak Integrity

1 X 10<sup>-4</sup> atm cc/sec of helium maximum

PRESSURE DROP	
Flow Rate	mbar
100 sccm	0.05
1 slpm	0.54
10 slpm	5.40
20 slpm	23
30 slpm	52
40 slpm	88
50 slpm	122

### Power Requirements

12 to 15 VDC, 15 VDC nominal, 100 mA maximum  
 24 VDC optional

### Output Signal

Linear 0 to 5 VDC, 1000 ohms minimum load resistance  
 Linear 4 to 20 mA, 500 ohms maximum loop resistance

### Display

3.5 digit LCD (0.6 in H); removable for remote mounting

## PHYSICAL SPECIFICATIONS

### Wetted Materials

10% glass-filled Nylon<sup>®</sup> 6/6, 316 stainless steel, nickel plating,  
 Viton<sup>®</sup> "O"-rings standard  
 Neoprene<sup>®</sup> and 4079 Kalrez<sup>®</sup> "O"-rings optional

© Nylon, Viton, Neoprene, Kal-Rez, and Teflon are registered trademarks of DuPont.

## ORDERING THE 822/824

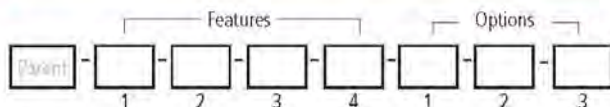

Instructions: To order the 822/824 please fill in each number block by selecting the codes from the corresponding features below and following pages.

Parent Number	
<b>822</b>	TopTrak® Mass Flow Meter with Display Flow body constructed of 10.0% glass-filled Nylon 6/6, with Viton® "O" rings and 316 stainless steel sensor. 3.5 digit LCD display. Linear, 0-5 VDC output signal, input power 12-15 VDC. Choice of inlet/outlet fittings, 9-pin "D" mating connector. Calibrated for flow ranges from 0-10 sccm to 0-50 slpm equivalent nitrogen flow; +/- 1.5% full scale accuracy; maximum temperature 122°F (50°C); maximum pressure 150 psig (10.3 barg). CE Approved.
<b>824</b>	TopTrak® Mass Flow Meter Same as above with no display.

Note: All slpm flow ranges also available in sccm  
You must select Low Flow Calibration under "Options" for 0-20 sccm full scale flow range or less.

Feature 1: Fittings	
<b>1</b>	1/8-inch compression for 822, 824 (maximum flow 5 slpm)
<b>2</b>	1/4-inch compression for 822, 824 (maximum flow 50 slpm)
<b>3</b>	3/8-inch compression for 822, 824
<b>5</b>	1/4-inch VCO for 822, 824 (maximum flow 50 slpm)
<b>8</b>	1/4-inch VCR for 822, 824 (maximum flow 50 slpm)
<b>10</b>	6 mm compression for 822, 824 (maximum flow 50 slpm)
<b>11</b>	10 mm compression for 822, 824
<b>13</b>	1/4-inch Female NPT for 822, 824
<b>19</b>	1/4-inch Female BSP
<b>20</b>	6 mm Festo push in fitting for polytube
<b>21</b>	1/4-inch Festo for polytube
<b>NX</b>	1/2-inch Female NPT for 826, 827 only

Option 2: Certificates	
<b>CC</b>	Certificate of conformance

Feature 2: Elastomers	
<b>OV1</b>	Viton®

Feature 3: Input Power	
<b>PV1</b>	12-15 VDC (see accessories for optional power supply)
<b>PV2</b>	24 VDC (customer must supply 24 VDC power)

Feature 4: Output Signal	
<b>V1</b>	0-5 VDC, linear
<b>V4</b>	4-20 mA, linear

Option 3: Special Cals	
<b>MP</b>	Medium pressure calibration (40-150 psig (2.8-10.3 barg))
<b>LF</b>	Low flow calibration (required for 0-20 sccm full scale flow range or less)

Option 5: Display	
<b>RD()</b>	Remote display. Maximum 100 feet available on models 822 or 826. Specify cable length in parentheses, \$1 per foot. Instruments ordered with remote display are not CE compliant.
<b>TD</b>	Totalizer and actual flow in display



# Appendix C 822S/824S Product Specifications

LOW FLOW BODY			MEDIUM FLOW BODY			HIGH FLOW BODY			
<b>FLOW RANGE</b>			<b>FLOW RANGE, slm</b>			<b>FLOW RANGE, slm</b>			
	0 to 10 sccm	0 to 15 slm		0 to 15	0 to 100		0 to 100	0 to 500	
<b>Process Tubing</b>	.25 (6.4)	.25 (6.4)	<b>Process Tubing</b>	.25 or .375 (6.4 or 9.5)	.25 or .375 (6.4 or 9.5)	<b>Process Tubing</b>	.375 or .5 (9.5 or 12.7)	.50 (12.7)	
<b>Fitting Type, .562-18 Thread<sup>(1)</sup></b>			<b>Fitting Type, .562-18 Thread<sup>(1)</sup></b>			<b>Fitting Type, .75-16 Thread<sup>(1)</sup></b>			
	Compression .125 or .25	VCO (male) .25	VCR (male) .25	Compression .25 or .375	VCO (male) .25 or .375	VCR (male) .25 or .375	Compression .375 or .50	VCO (male) .775	VCR (male) .775
<b>Dim. L</b>	4.84 or 5.0 (122.9 or 127.0)	4.60 (116.8)	4.90 (124.5)	6.27 or 6.39 (159.3 or 162.3)	5.81 or 6.25 (147.6 or 158.8)	6.13 or 6.43 (155.7 or 163.3)	11.89 or 12.17 (302 or 309.1)	11.75 (298.5)	12.19 (309.6)

Note: (1) Metric fittings are available, consult factory.

Model 820S—Side View

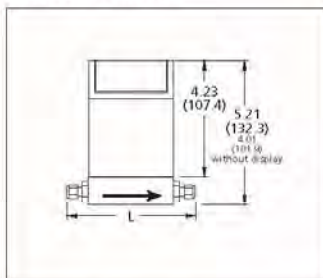

Model 820S—Bottom View

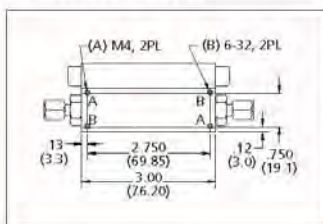

Model 820S—Outlet View

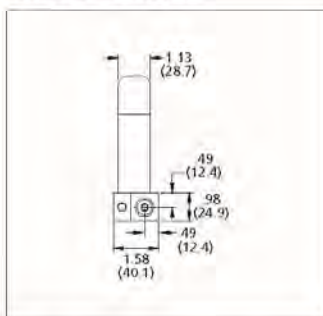

Model 820S—Side View

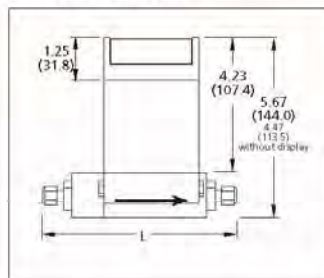

Model 820S—Bottom View

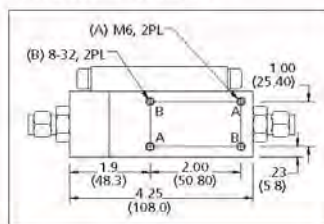

Model 820S—Outlet View

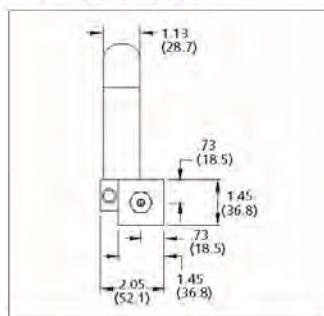

Model 820S—Side View

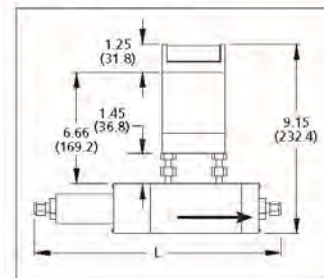

Model 820S—Bottom View

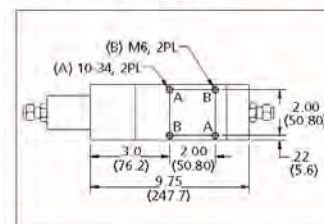

Model 820S—Outlet View

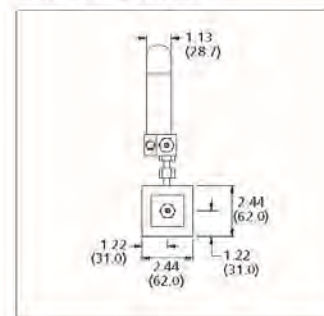

All dimensions are inches. Millimeters are in parentheses. Certified drawings are available on request.

## PERFORMANCE SPECIFICATIONS

### Accuracy

± 1.5% of full scale under calibration conditions including linearity over 15° to 25°C and 5 to 60 psia (0.3 to 4 bara)

If the meter is mounted with a vertical (up or down) flow path the following accuracy de-rating applies:

Operating Pressure			
Inlet Pressure Deviation <sup>2</sup>	50 psig	100 psig	150 psig
± 1 psig	± 1.5% of full scale	± 1.5% of full scale	± 1.5% of full scale
± 5 psig	± 3.8% of full scale	± 4.5% of full scale	± 5.3% of full scale
± 10 psig	± 6% of full scale	± 7.5% of full scale	± 9% of full scale

Notes: (1) Do not exceed 150 psig. (2) Difference between inlet pressure and calibrated pressure. Do not exceed ± 10 psig.

### Repeatability

± 0.5% of full scale

### Temperature Coefficient

0.08% of full scale per °F (0.15% of full scale per °C), or better

### Pressure Coefficient

0.01% of full scale per psi (0.15% of full scale per bar) or better

### Response Time

800 ms time constant; six seconds (typical) to within ± 2% of final value over 25 to 100% of full scale

## OPERATING SPECIFICATIONS

### Gases

Most gases; check compatibility with wetted materials; specify when ordering

### Mass Flow Rates

0 to 10 sccm to 0 to 500 slpm; flow ranges specified are for an equivalent flow of nitrogen at 760 mm Hg and 21°C (70°F); other ranges in other units are available (e.g., scfh or nm<sup>3</sup>/h)

### Gas Pressure

500 psig (34 barg) maximum;  
For pressures > 500 psig (34 barg), consult C100/M100 HP SmartTrak  
30 psig (2 barg) optimum

### Gas & Ambient Temperature

32 to 122°F (0 to 50°C)

### Leak Integrity

5 X 10<sup>-9</sup> atm cc/sec of helium maximum

### Power Requirements

12 to 15 VDC, 15 VDC nominal, 100 mA maximum  
24 VDC optional, specify when ordering

### Output Signal

Linear 0–5 VDC, 1000 ohms minimum load resistance  
Linear 4–20 mA, 500 ohms maximum loop resistance

### Display (optional)

3.5 digit LCD (0.6 in H); removable for remote mounting

## PHYSICAL SPECIFICATIONS

### Wetted Materials

316 stainless steel, Viton® "O"-rings standard  
Neoprene® and 4079 Kalrez® "O"-rings optional

### Options

See "Price List" for available CE options

© Viton, Neoprene, Kalrez, and Teflon are registered trademarks of DuPont.

PRESSURE DROP ACROSS THE 8205							
Flow Meter	Flow rate	psi			Mbar		
Meter Fittings (inch)		1/4	3/8	1/2	1/4	3/8	1/2
8205	100 sccm	.005	n/a	n/a	.309	n/a	n/a
8205	500 sccm	.006	n/a	n/a	.440	n/a	n/a
8205	1 slpm	.006	n/a	n/a	.475	n/a	n/a
8205	15 slpm	.11	.06	n/a	7.59	4.0	n/a
8205	20 slpm	.08	.03	n/a	5.50	2.0	n/a
8205	50 slpm	n/a	.3	.10	n/a	20.4	6.8
8205	100 slpm	2.0	.85	.30	136	58	20.4
8205	200 slpm	n/a	2.50	2.00	n/a	170	136
8205	500 slpm	n/a	n/a	8.5	n/a	n/a	578

## ORDERING INFORMATION

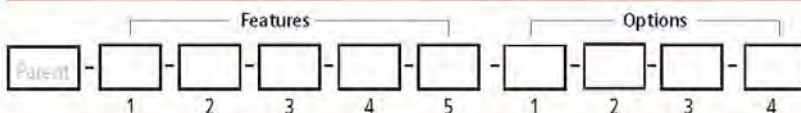

Instructions: To order a 8205/840 please fill in each number block by selecting the codes from the corresponding features below and following pages.

Parent Number	
822S	Top-Trak® Mass Flow Meter with Display. Flow body and sensor constructed of 316 stainless steel, Viton® "O"-rings. 3.5 digit LCD display. Linear, 0-5 VDC output signal; input power 12-15 VDC. 9 Pin "D" mating connector and 1/4-inch fitting. Calibrated for flow ranges from 0-10 sccm to 0-500 slpm equivalent nitrogen flow; 1.5% full scale accuracy; maximum temperature 122°F (50°C); maximum pressure 500 psig (34.5 barg) for horizontal orientation; maximum pressure 150 psig (10.3 barg) for vertical orientation. CE Approved.
824S	Top-Trak® Mass Flow Meter. Same as above with no display.

Feature 1: Flow Body*	
L	822S-L with display (0-10 sccm up to 0-15 slpm)
L	824S-L without local display (0-10 sccm up to 0-15 slpm)
M	822S-M with display (0-15 slpm up to 0-100 slpm) (also see M100M)
M	824S-M without local display (0-15 slpm up to 0-100 slpm)
H	822S-H with display (0-100 slpm up to 0-500 slpm) (also see M100H)
H	824S-H without local display (0-100 slpm up to 0-500 slpm)

NOTE: ALL SLPM FLOW RANGES ALSO AVAILABLE IN NLPM

Feature 2: Elastomers	
OV1	Viton®. For low, medium and high flow bodies
ON1	Neoprene®. For low and medium flow bodies
ON2	Neoprene®. For high flow bodies
OK1	Kalrez®. For low flow bodies
OK2	Kalrez®. For medium flow bodies
OK3	Kalrez®. For high flow bodies

Feature 4: Input Power	
PV1	12-15 VDC
PV2	24 VDC

Feature 5: Output Signal	
V1	0-5 VDC, linear
V4	4-20 mA, linear

Feature 3: Fittings	
1	1/8-inch compression. For low flow bodies (maximum 5 slpm)
2	1/4-inch compression. For low and medium flow bodies (maximum 50 slpm)
3	3/8-inch compression. For low, medium and high flow bodies (maximum 300 slpm)
4	1/2-inch compression. For medium and high flow bodies
5	1/4-inch VCO. For low and medium flow bodies (maximum 50 slpm)
6	1/2-inch VCO. For low and medium flow bodies
7	1/2-inch VCO. For high flow bodies. (maximum 300 slpm)
8	1/4-inch VCR. For low and medium flow bodies (maximum 50 slpm)
9	1/2-inch VCR. For low, medium and high flow bodies
10	6 mm compression. For low and medium flow bodies (maximum 50 slpm)
11	10 mm compression. For medium and high flow bodies
12	12 mm compression. For medium and high flow bodies
13	1/4-inch FNPT adapter bushing. For low and medium flow bodies
14	3/8-FNPT. For low and med flow bodies only.
19	1/4-inch Female BSP
20	6 mm Festo push in fitting for polytube
21	1/4-inch Festo for polytube

Option 2: Certifications	
MC	Material certificates--US Mill certs on all wetted flow body parts
CC	Certificate of conformance

Option 1: Special Cal.	
HP*	High pressure calibration. 100-500 psig maximum (6.9-34.5 barg)
MP	Medium pressure calibration. 40-100 psig (2.8-6.9 barg)
LF	Low Flow calibration. Required for 0-20 sccm full scale flow range or less

\* Maximum pressure 150 psig (10.3 barg) for vertical flow orientation.

Option 4: Display	
RD( )	Remote Display. Maximum 100 feet available on Models 822S. Specify cable length in parentheses, \$1 per foot. Instruments ordered with remote display are not CE compliant
T	Totalizer + actual flow in display (model 822S and 826)

Option 3: O2 Cleaning	
O2C	O2 Cleaning. Includes certification. Product cleaned for O2 service. Inspected with ultra-violet light, double-bagged prior to shipment.

## Appendix D 826/827 Product Specifications

### PERFORMANCE SPECIFICATIONS

#### Accuracy

±/− 1.5% of Full Scale under calibration conditions including linearity over 59°F to 77°F (15°C to 25°C) and 5 to 60 psia (0.3 to 4 bara)

Inlet Pressure Deviation <sup>2</sup>	Operating Pressure		
	50 psig	100 psig	150 psig
± 1 psig	± 1.5% of full scale	± 1.5% of full scale	± 1.5% of full scale
± 5 psig	± 3.8% of full scale	± 4.5% of full scale	± 5.3% of full scale
± 10 psig	± 6% of full scale	± 7.5% of full scale	± 9% of full scale

#### Repeatability

±/− 0.5% of full scale

#### Temperature Coefficient

0.08% of full scale per °F (0.15% of full scale per °C), or better

#### Pressure Coefficient

0.01% of full scale per psi (0.15% of full scale per bar), or better

#### Response Time

800 ms time constant, six seconds (typical) to within ±/− 2% of final value over 25 to 100% of full scale

### OPERATING SPECIFICATIONS

#### Gases

Most gases; check compatibility with wetted materials, specify when ordering

#### Mass Flow Rates

0 to 75 up to 0 to 175 slpm; flow range is for an equivalent flow of nitrogen at 760 mm Hg and 21°C (70°F); other ranges in other units are available (e.g., scfh or nm<sup>3</sup>/h)

#### Gas Pressure

150 psig (10 barg) maximum  
20 psig (1.4 barg) optimum

#### Pressure Drop

15.0 mbar at 75 slpm  
67.8 mbar at 175 slpm

#### Gas & Ambient Temperature

32 to 122°F (0 to 50°C)

#### Leak Integrity

1 X 10<sup>-4</sup> atm cc/sec of helium maximum

#### Power Requirements

12 to 18 VDC, 15 VDC nominal, 100 mA maximum  
24 VDC optional

#### Output Signal

Linear 0 to 5 VDC, 1000 ohms minimum load resistance  
Linear 4 to 20 mA, 500 ohms maximum loop resistance

#### Display

3.5 digit LCD (0.6 in H); removable for remote mounting

### OPERATING SPECIFICATIONS

#### Wetted Material

Anodized aluminum, 316 stainless steel, nickel plating, Viton®  
"O"-rings standard; Neoprene and 4079 Kalrez® "O"-rings optional

Straight Pipe Length Requirements (In Number of Internal Diameters, D)	
1/2 inch Female NPT, minimum, upstream	10 D
1/2 inch Female NPT, minimum, downstream	5 D

® Viton, Neoprene, Kal Rez, and Teflon are registered trademarks of DuPont

**DIMENSIONS**

**826—Side View**

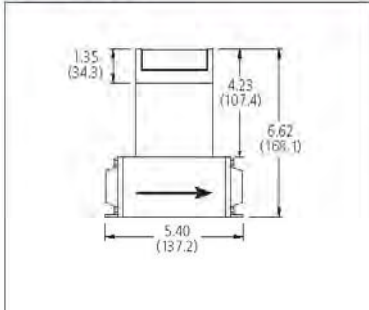

**826—Outlet View**

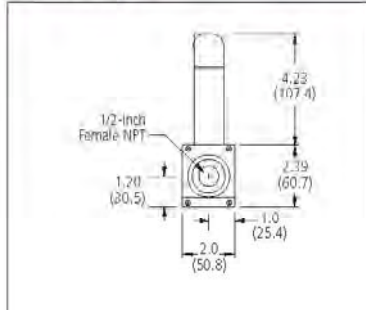

**826—Bottom View**

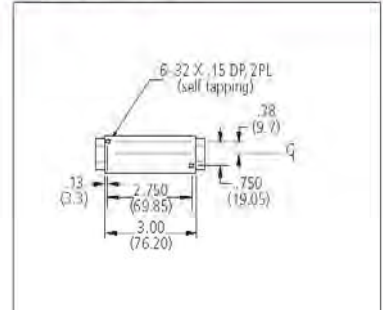

**827—Side View**

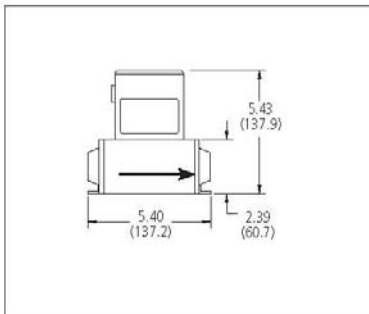

**827—Outlet View**

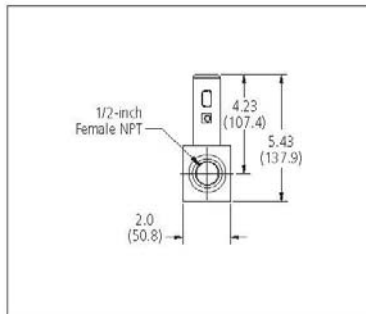

**827—Bottom View**

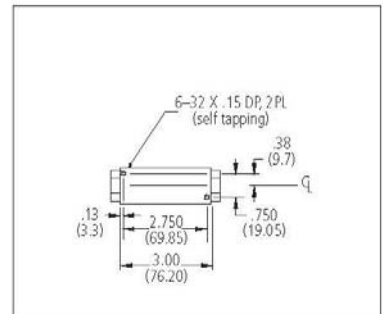

All dimensions are inches and in parentheses are millimeters. Certified drawings are available on request.

**ORDERING THE 826/827**

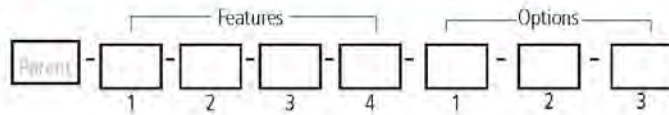

Instructions: To order the 826/827 please fill in each number block by selecting the codes from the corresponding features below and following pages.

Parent Number	
<b>826</b>	TopTrak® Hi-Flow Mass Flow Meter with Display Remember this meter requires 10 diameters up-stream and 5 downstream for optimum performance. Flow body constructed of aluminum, with Viton® "O" rings and 316 stainless steel sensor. 3.5 digit LCD display. Linear, 0-5 VDC output signal; input power 12-15 VDC. 1/2-inch FNPT inlet/outlet fittings; 9-pin "D" mating connector. Calibrated for flow ranges from 0-75 slpm up to 0-175 slpm equivalent nitrogen flow; +/- 1.5% full scale accuracy; maximum temperature 122°F (50°C); maximum pressure 150 psig (10.3 barg). CE Approved.
<b>827</b>	TopTrak® Hi-Flow Mass Flow Meter. Same as above with no display.

Note: All slpm flow ranges also available in sccm. You must select Low Flow Calibration under "Options" for 0-20 sccm full scale flow range or less. Model 826 and 827 require upstream and downstream straight, non restricted 1/2" pieces of pipe. See Instruction Manual for specifics on straight run requirements for the Models 826 and 827 only.

Feature 1: Fittings	
<b>1</b>	1/8-inch compression for 822, 824 (maximum flow 5 slpm)
<b>2</b>	1/4-inch compression for 822, 824 (maximum flow 50 slpm)
<b>3</b>	3/8-inch compression for 822, 824
<b>5</b>	1/4-inch VCO for 822, 824 (maximum flow 50 slpm)
<b>8</b>	1/4-inch VCR for 822, 824 (maximum flow 50 slpm)
<b>10</b>	6 mm compression for 822, 824 (maximum flow 50 slpm)
<b>11</b>	10 mm compression for 822, 824
<b>13</b>	1/4-inch Female NPT for 822, 824
<b>19</b>	1/4-inch Female BSP
<b>20</b>	6 mm Festo push in fitting for polytube
<b>21</b>	1/4-inch Festo for polytube
<b>NX</b>	1/2-inch Female NPT for 826, 827 only

Option 3: Display	
<b>RD( )</b>	Remote display. Maximum 100 feet available on models 822 or 826. Specify cable length in parentheses; \$1 per foot. Instruments ordered with remote display are not CE compliant.
<b>T</b>	Totalizer and actual flow in display

Feature 2: Elastomers	
<b>OV1</b>	Viton®

Feature 3: Input Power	
<b>PV1</b>	12-15 VDC (see accessories for optional power supply)
<b>PV2</b>	24 VDC (customer must supply 24 VDC power)

Feature 4: Output Signal	
<b>V1</b>	0-5 VDC, linear
<b>V4</b>	4-20 mA, linear

Option 1: Special Lots	
<b>MP</b>	Medium pressure calibration (40-150 psig (2.8-10.3 barg))
<b>LF</b>	Low flow calibration (required for 0-20 sccm full scale flow range or less)

Option 2: Certificates	
<b>CC</b>	Certificate of conformance