



EGM-SERIES ELECTRONIC FLOWMETER

All EGM-Series pulse meters are designed for volumetric flow measurement of clean liquids across a broad range of applications in the automotive, aviation, mining, power, chemical, pharmaceutical, and petroleum industries. The EGM-Series will produce accurate and reliable measurements of almost all clean liquids, including but not limited to; alcohols, fuels and oils, water based salts and solutions, corrosion inhibitors, brake and transmission fluids, greases, emulsifiers, adhesives, insecticides, and some aggressive chemicals.

FEATURES / BENEFITS

- Oval Gear technology for high accuracy and repeatability
- Direct volumetric measurement of flow
- Accuracy of reading is not affected by temperature and viscosity changes
- Measures high and low viscosity liquids
- Only two moving parts
- "Fuel Consumption" option can tolerate flow pulsations and has a built-in temperature sensor to correct for the fuel density changes

GENERAL SPECIFICATIONS

- **Flow rates:** 0.26 GPH - 21.1 GPM (1 L/hr - 80 L/min)
- **Sizes:** 1/8" - 3/4" (4 mm - 20 mm)
- **Temperature range:** 5°F - +176°F (-15°C - +80°C)

CALIBRATION

EGM-Series flowmeters are available with factory calibrations or can be calibrated in the field as an economical option.

FUEL CONSUMPTION

EGM-Series flowmeters with the Fuel Consumption option (Integral Option 2) are equipped with an integral PT100 temperature sensor which allows for accurate measurement of fuel consumption on combustion engines by correcting for temperature differences from the inlet to outlet of the engine. It also includes the Pulsating Flow electronics that eliminate the effect of pulsations in the flow.

PRODUCT CONFIGURATION

PRODUCT IDENTIFIER **1**

- EGM004** = 1/8" (4 mm) 0.26 - 9.6 GPH (1-36 L/hr)
- EGM006** = 1/4" (6 mm) 0.5 - 27 GPH (2-100 L/hr)
- EGM008** = 3/8" (8 mm) 4 - 145 GPH (15-550 L/hr)
- EGM015** = 1/2" (15 mm) 0.26 - 10.6 GPM (1-40 L/min)
- EGM020** = 3/4" (20 mm) 0.5 - 21 GPM (3-80 L/min)

MATERIALS **2**

- A00** = Aluminum / PPS / No bearing (EGM008-020)
- A51** = Aluminum / Stainless Steel / Carbon Ceramic (EGM004-015)
- A52** = Aluminum / Stainless Steel / Bronze (EGM004-015)
- S00** = 316 Stainless Steel / PPS / No bearing (EGM008-020)
- S51** = 316 Stainless Steel / Stainless Steel / Carbon Ceramic (EGM004-015)

O-RING MATERIALS **3**

- 1** = Viton (5°F min. [-15°C])
- 3** = Teflon encapsulated Viton (5°F min. [-15°C])
- 4** = Nitrile, (-40°F min. [-40°C])

TEMPERATURE **4**

- 8** = 176°F (80°C) max

PROCESS CONNECTION **5**

- 1** = BSPP (G) female threaded (ISO 228)
- 2** = NPT female threaded

INTEGRAL OPTIONS **6**

- 0** = Hall effect output (no calibration) (2 m cable)
- 1** = Hall effect output with one point calibration and K-Factor (2 m cable)^*
- 2** = Fuel consumption (Pulsating flow, PT100 temp. sensor, one pt Cal & K-factor) (2 m cable)^*

--->>>> **1** **2** **3** **4** **5** **6**
 --->>>> EGM008 A00 1 8 1 2

^Statement of conformance K-Factor printed on meter

*Calibration sheet can be ordered

APPLICATIONS

- Aluminum meters with PPS rotors are suitable for petroleum products including: oils, greases, fuels and fuel oils.
- Aluminum meters with stainless steel rotors and bronze bearings are suitable for petroleum products including: fuels with high Benzene content, automotive brake fluid, and some solvents such as turpentine.
- Stainless steel meters are suitable for alcohols, water based liquids, some aggressive liquids, AdBlue (DEF, Urea) as well as fuel and oil applications in saline marine environments.

SPECIFICATIONS

	EGM004	EGM006	EGM008	EGM015	EGM020
Nominal Size:	1/8" [4 mm]	1/4" [6 mm]	3/8" [8 mm]	1/2" [15 mm]	3/4" [20 mm]
Nominal Flow Range* @ 3cP:	1 - 36 L/hr	2-100 L/hr	15-550 L/hr	1-40 L/min	3-80 L/min
	0.26-9.5 GPH	0.5-27 GPH	4-145 GPH	.26-10.6 GPM	0.8-21 GPM
Flow Range @ 1cP	2-24 L/hr	5-80 L/hr	18-440 L/hr	1.5-32 L/min	5-64 L/min
	0.25-6.34 GPH	1.32-21.13 GPH	4.76-116.24 GPH	0.39-8.45 GPM	1.32-16.91 GPM
Flow Range @ 7cP	0.5-36 L/hr	1-100 L/hr	15-550 L/hr	0.5-40 L/min	2-80 L/min
	0.13-9.51 GPH	0.26-26.42 GPH	3.96-145.29 GPH	0.13-10.57 GPM	0.53-21.13 GPM
Flow Range @ 200cP	0.4-36 L/hr	0.7-100 L/hr	6-550 L/hr	0.4-40 L/min	1.8-80 L/min
	0.10-9.51 GPH	0.18-26.42 GPH	1.58-145.29 GPH	0.10-10.56 GPM	0.47-21.13 GPM
Flow Range @ 500cP	0.25-27 L/hr	0.5-75 L/hr	2-550 L/hr	0.3-40 L/min	1.5-80 L/min
	0.06-7.13 GPH	0.13-19.81 GPH	0.25-145.29 GPH	0.08-10.56 GPM	0.39-26.42 GPM
Flow Range @ 1000cP	0.12-16 L/hr	0.3-45 L/hr	1.5-360 L/hr	0.2-25 L/min	1-50 L/min
	0.03-4.22 GPH	0.08-11.89 GPH	0.39-95.10 GPH	0.05-6.6 GPM	0.26-13.21 GPM
Accuracy*:	±1% of reading			±0.5% of reading	
Repeatability:	Typically ± 0.03% of reading				
Ambient Temperature Range:	5°F - +176°F (-15°C - +80°C)				
Fluid Temperature Range:	23°F - +176°F (-5°C - +80°C)				
Max. Pressure (AI meters):	500 psi [34 bar]	500 psi [34 bar]	500 psi [34 bar]	290 psi [20 bar]	290 psi [20 bar]
Max. Pressure (SS meters):	800 psi [55 bar]	800 psi [55 bar]	500 psi [34 bar]	290 psi [20 bar]	290 psi [20 bar]
Protection Class:	IP65				
Recommended Filtration:	200 mesh [75 µm]			100 mesh [150 µm]	
Pulse Output Type:	NPN Open Collector (Hall Effect Sensor)				
Voltage:	5 - 24 V (dc)				
Current Draw:	20mA max.				
Switching Current:	10mA max.				
Pulse Output Resolution - Standard Pulse/USG [Pulse/L]	10600 [2800]	4012 [1060]	2725 [720]	644 [170]	398 [105]
Pulse Output Resolution - Fuel Cons. Option Pulse/USG [Pulse/L]	10600 [2800]	4012 [1060]	681 [180]	161 [42.5]	99.5 [26.3]
RTD Specification (Integral Option 2)	Platinum Resistance Thermometer 100 Ohms (PT100) Class F0.3				

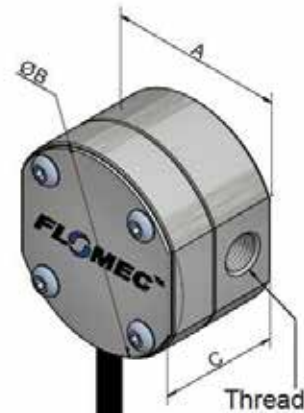

DIMENSIONS

Model:	A	B	C
EGM004	1.81" [46 mm]	1.95" [49.5 mm]	1.38" [35 mm]
EGM006	2.28" [58 mm]	2.54" [64.5 mm]	1.54" [39 mm]
EGM008	2.28" [58 mm]	2.54" [64.5 mm]	1.93" [49 mm]
EGM015	2.84" [72 mm]	3.23" [82 mm]	2.60" [66 mm]
EGM020	2.84" [72 mm]	3.23" [82 mm]	3.03" [77 mm]

*Maximum flow reduces as viscosity increases, see flow de-rating guide.
Max recommended Pressure drop is 14.5 psi (1 bar).

*When used to meter rate, at very low flow rates, the rate can jump, due to resolution (not accuracy).